

VEX IQ

Build Instructions Montageanleitung

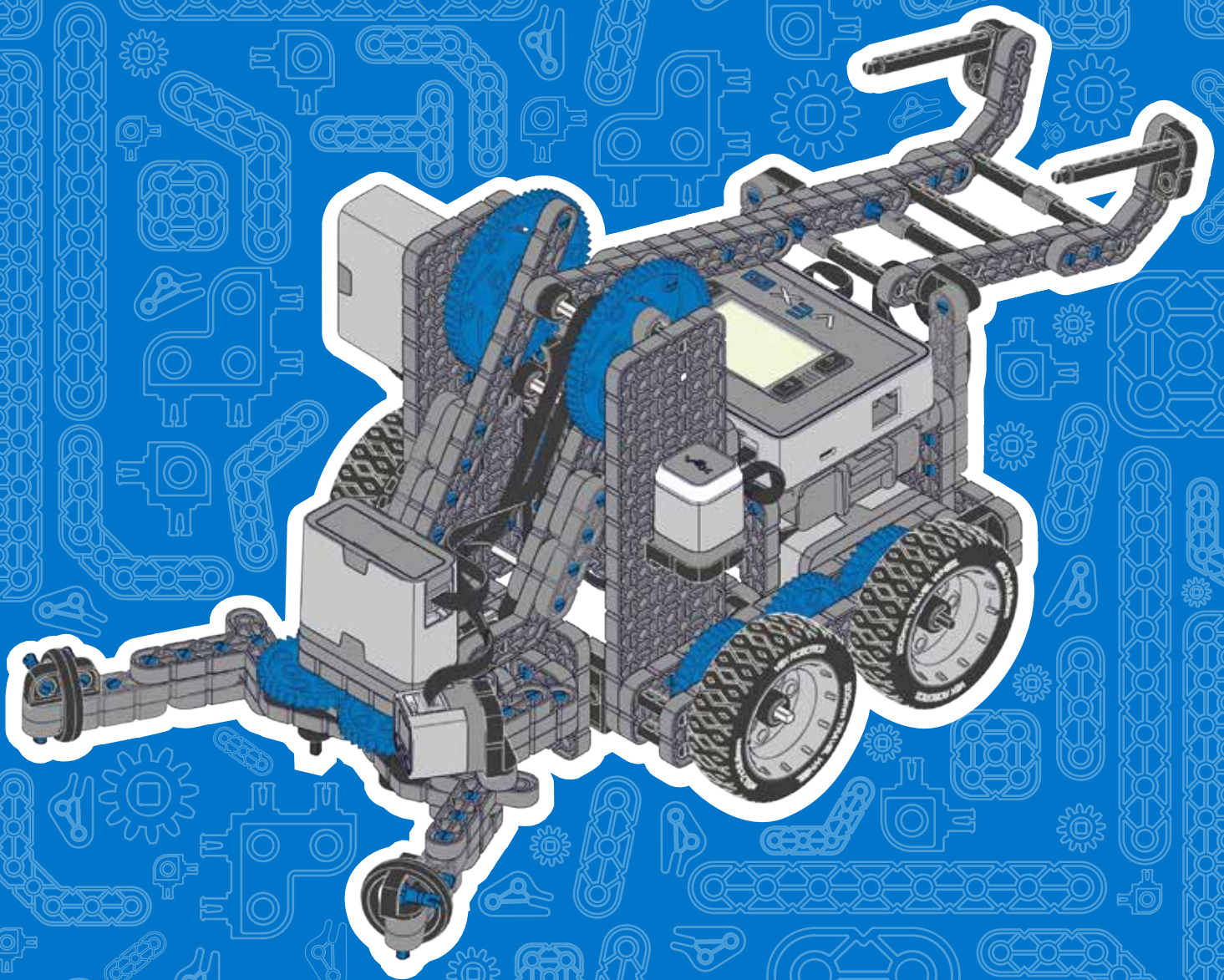

Includes plans for
all four robots | Anleitung für alle
vier Roboter



Table of Contents Inhaltsverzeichnis

i	VEX IQ Assembly Tips Montagehinweise zum VEX IQ	3
----------	--	----------

1	Standard Drive Base Standard-Fahrwerk	4
----------	--	----------

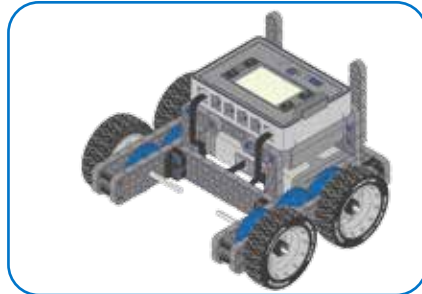

Build Steps Aufbauschritte	1-19
---------------------------------------	-------------

2	Clawbot IQ	10
----------	-------------------------	-----------



Build Steps Aufbauschritte	20-87
---------------------------------------	--------------

3	Clawbot IQ with Sensors Clawbot IQ mit Sensoren	28
----------	--	-----------



Build Steps Aufbauschritte	88-101
---------------------------------------	---------------

4	Autopilot Instructions Anweisungen für den Autopiloten	32
----------	---	-----------



Build Steps Aufbauschritte	102-117
---------------------------------------	----------------

VEX IQ Assembly Tips: Montagehinweise zum VEX IQ: i

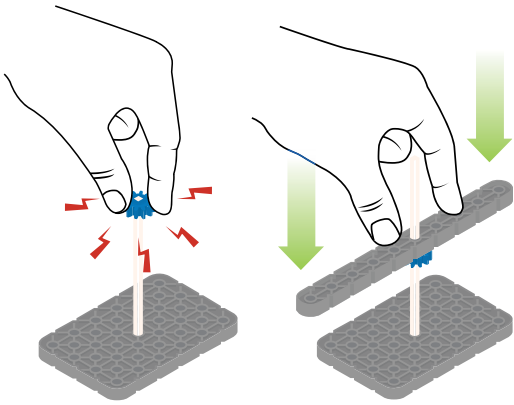

Use a 1x Beam for extra leverage when mounting small VEX IQ elements on shafts.
1x Träger können als Extra-Hebel verwendet werden, um kleine VEX-IQ-Elemente auf Wellen zu montieren.

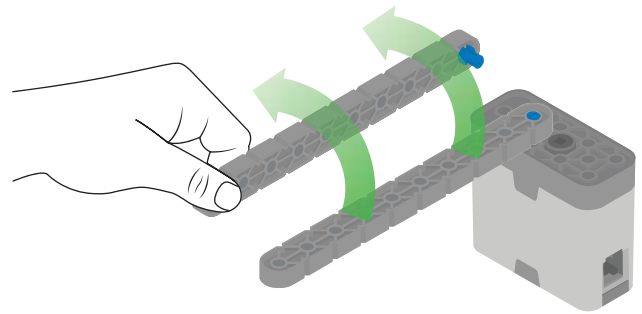

Connector Pins can be smoothly removed from Smart Motors, Sensors, or Robot Brains using a 1x Beam. Put the 1x Beam onto the pin and twist the Beam while pulling outward.
Verbindungsstifte können mit einem 1x Träger leicht von Smart Motoren, Sensoren oder vom Robot Brain entfernt werden. Dazu den 1x Träger auf den Stift setzen und beim Herausziehen seitlich drehen.

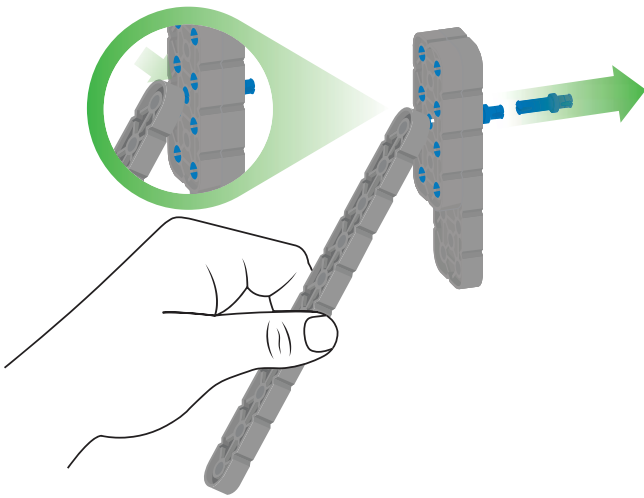

Quickly remove Connector Pins by pressing a VEX IQ Beam against the back of the Pin and pulling it out.
Verbindungsstifte können schnell entfernt werden, indem ein VEX IQ Träger gegen die Rückseite des Stifts gedrückt wird.

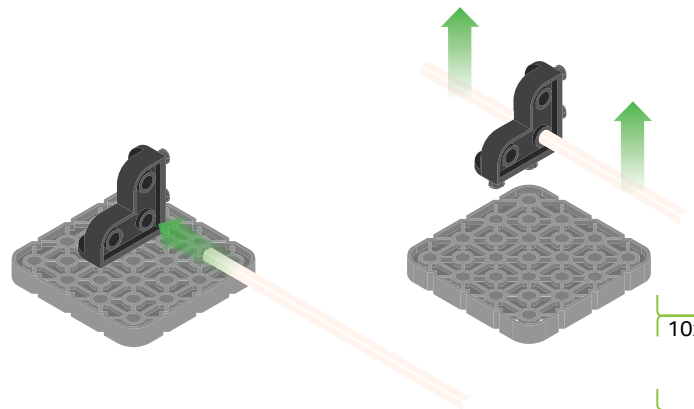

Easily remove Corner Connectors by placing a metal shaft through one of the holes and pulling outward.
Winkelverbinder sind leicht zu entfernen, indem eine Metallwelle durch eins der Löcher gesteckt und der Verbinder dann abgezogen wird.

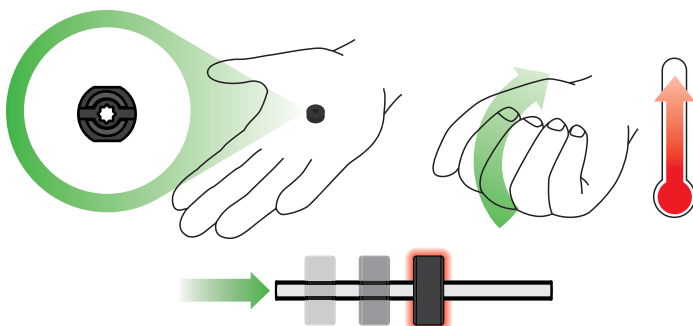

Rubber Shaft Collars become softer and easier to install if they are warmed by holding them in your hand for 15-30 seconds.
Wellenbünde aus Gummi werden weicher und leichter zu installieren, wenn sie vorher 15 bis 30 Sekunden lang in der Hand aufgewärmt wurden.

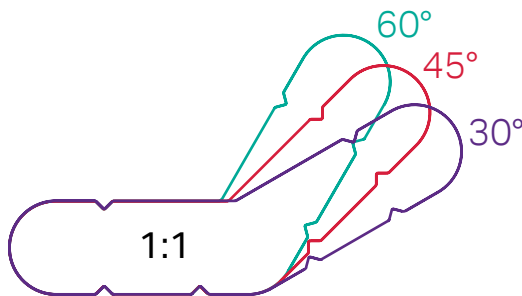

The best way to measure an Angle Beam is to compare it against known angles (such as above). To measure Shaft length, set it alongside a VEX IQ Beam and count the notches.

Die beste Art, einen Winkelträger zu vermessen, besteht darin, ihn mit bekannten Winkeln zu vergleichen (wie oben). Die Länge einer Welle entspricht der Anzahl der Kerben auf einem VEX IQ Träger.

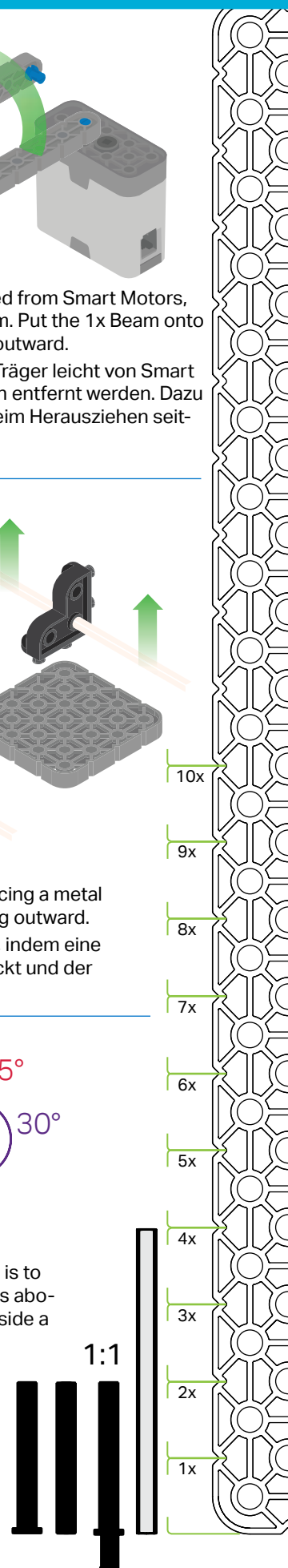

1 Standard Drive Base Standard-Fahrwerk

1

Required parts
Erforderliche Teile

6x 228-2500-060

1x 228-2500-026

1x 228-2560

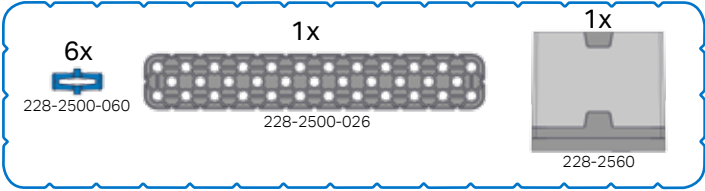

Look for Quey for build tips
Quey zeigt Aufbautipps

Completed build step
Aufbauschnitt abgeschlossen

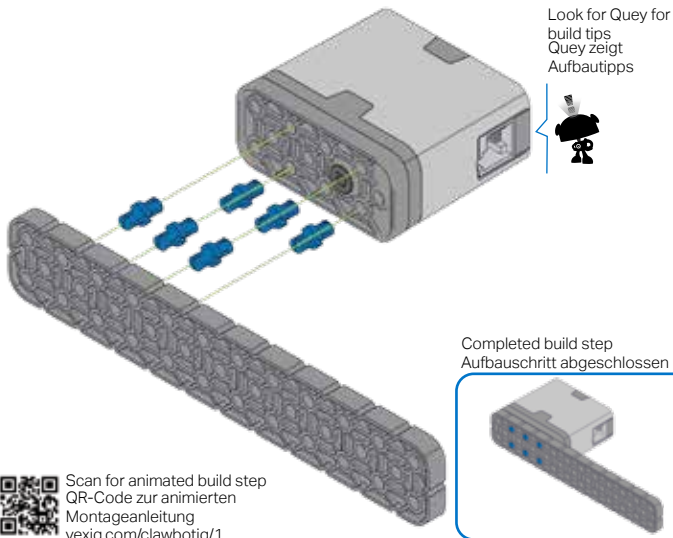

Scan for animated build step
QR-Code zur animierten
Montageanleitung
vexiq.com/clawbotiq/1

2

1x 228-2500-214

1x 228-2500-143

1x 228-2500-120 (4xP)

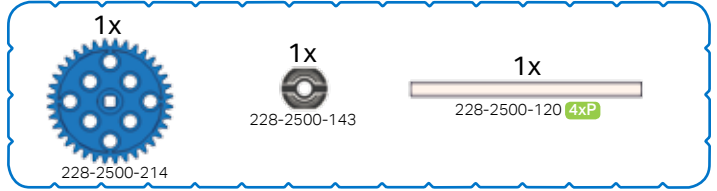

1:1

Use a 1x beam as guide for position on shaft
Verwenden Sie einen 1x Träger als Führung für die richtige Positionierung auf der Welle

1x

vexiq.com/clawbotiq/2

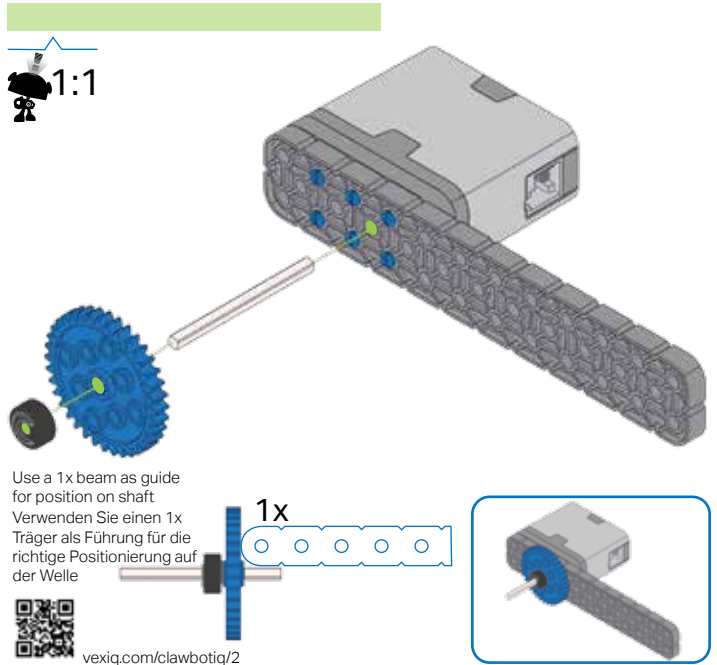

3

2x 228-2500-062

2x 228-2500-065

1x 228-2500-135

1x 228-2500-145

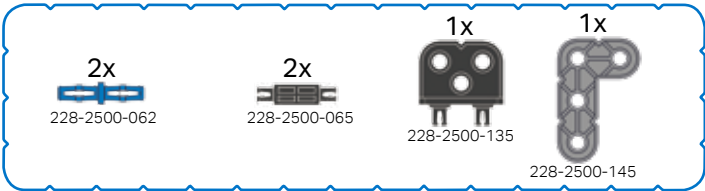
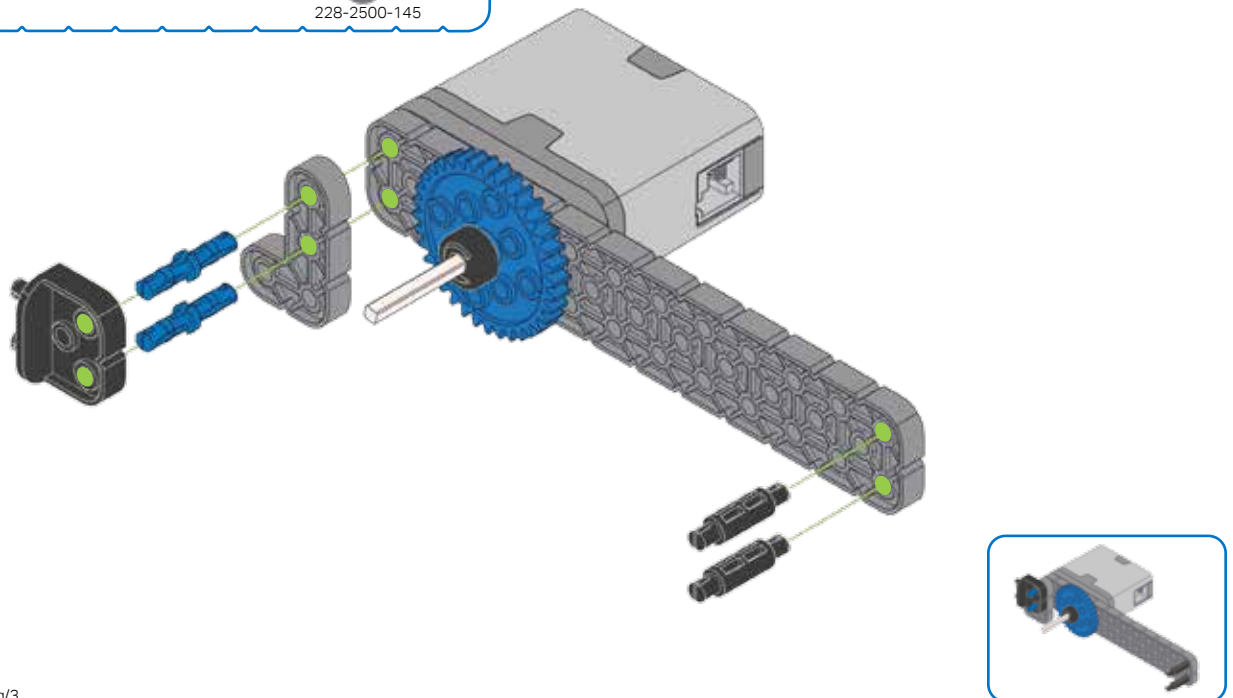
vexiq.com/clawbotiq/3

4

2x
228-2500-214

2x
228-2500-143

1x
228-2500-074 2xP

1x
228-2500-122 6xP

1:1

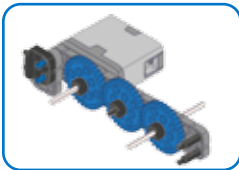
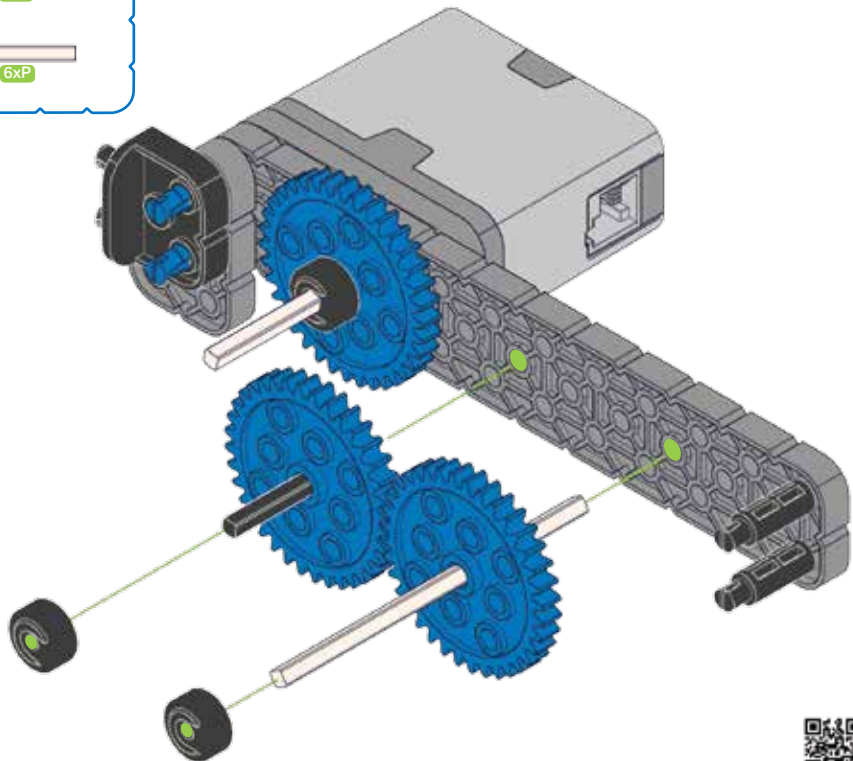
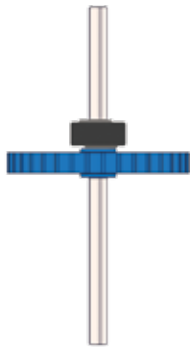

vexiq.com/clawbotiq/4 

5

1x
228-2500-026

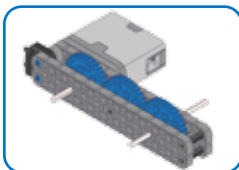
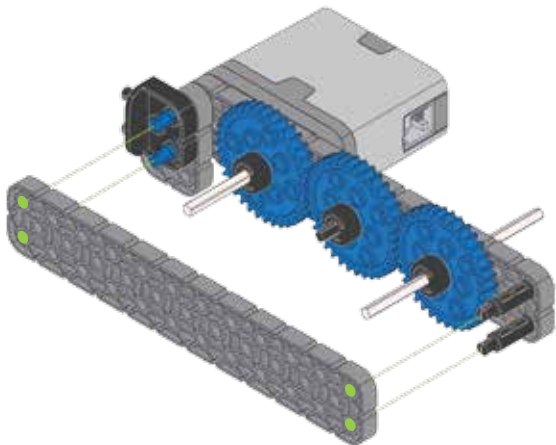

 vexiq.com/clawbotiq/5

6

2x
228-2500-208

2x
228-2500-143

2x
228-2500-209

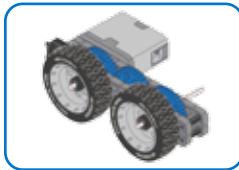
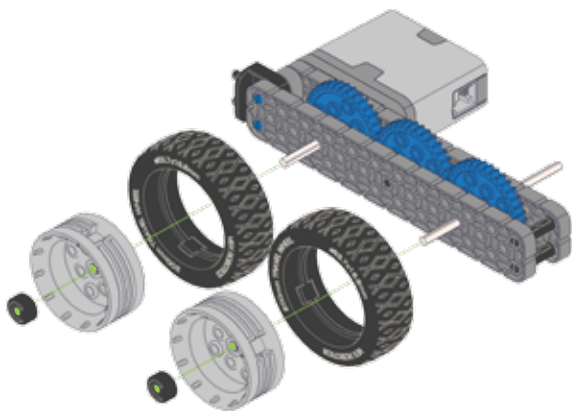

 vexiq.com/clawbotiq/6

7

6x 228-2500-060

1x 228-2500-026

1x 228-2560

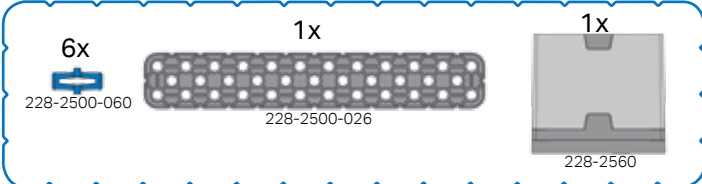
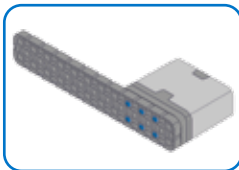
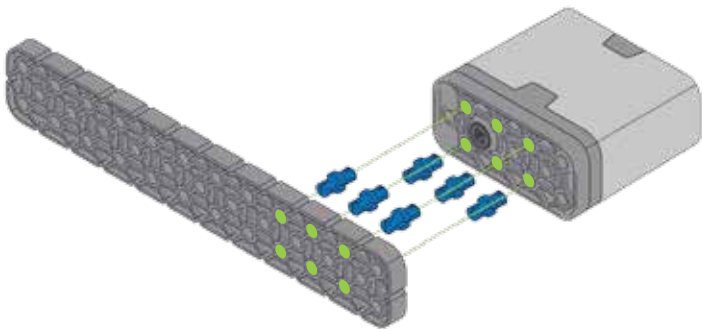
vexiq.com/clawbotiq/7

8

1x 228-2500-214

1x 228-2500-143

1x 228-2500-120 4xP

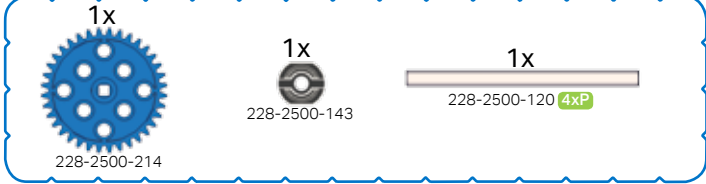
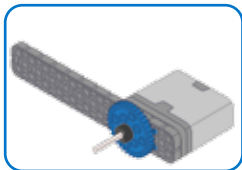
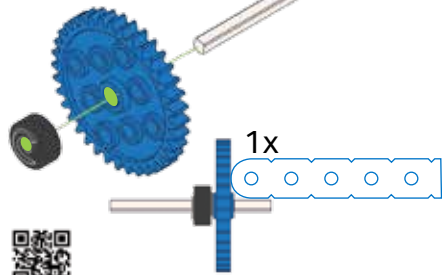
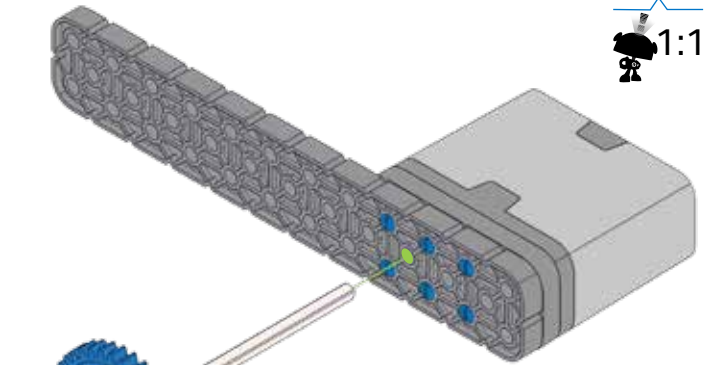
vexiq.com/clawbotiq/8

9

2x 228-2500-062

2x 228-2500-065

1x 228-2500-135

1x 228-2500-145

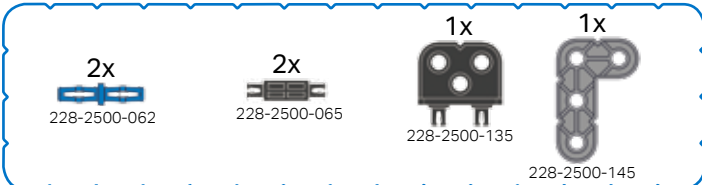
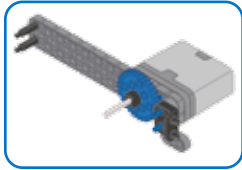
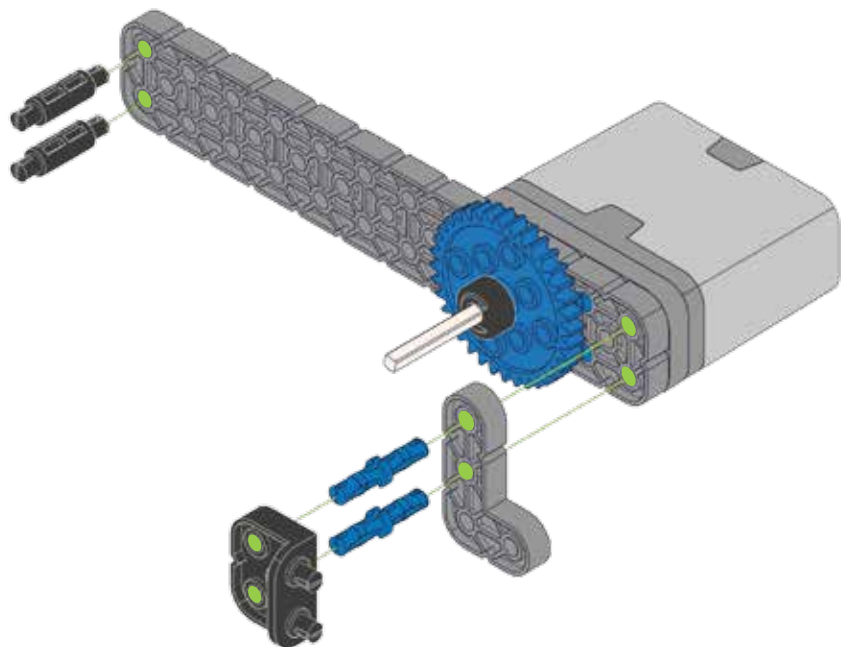
vexiq.com/clawbotiq/9

10

2x
228-2500-214

2x
228-2500-143

1x
228-2500-074 2xP

1x
228-2500-122 6xP

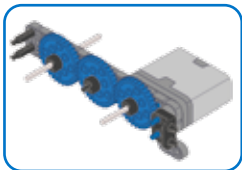
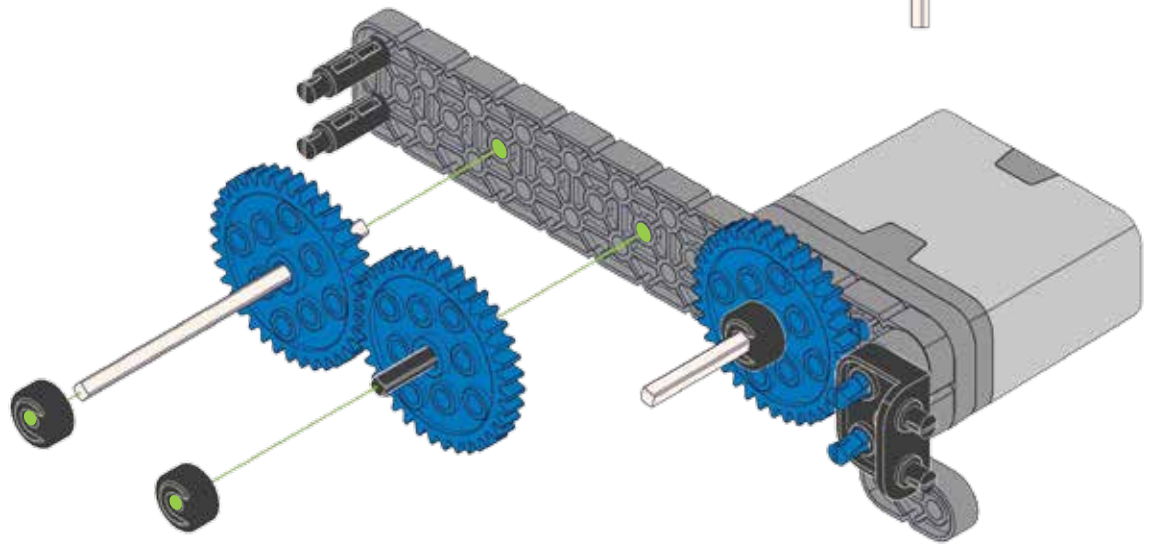
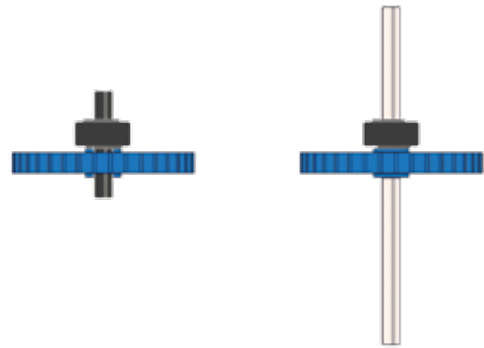

11

1x
228-2500-026

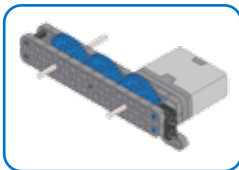
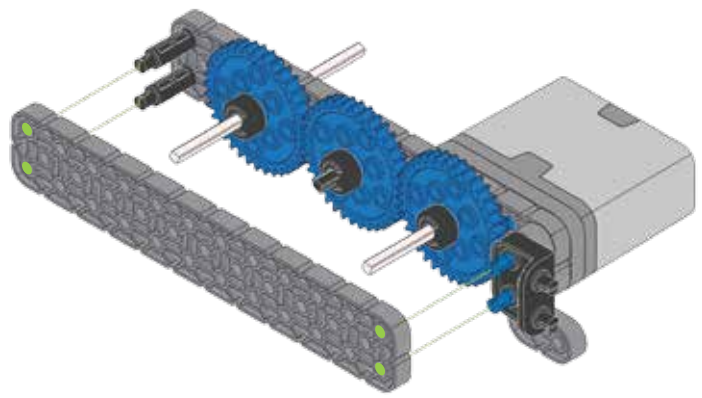

12

2x
228-2500-208

2x
228-250-143

2x
228-2500-209

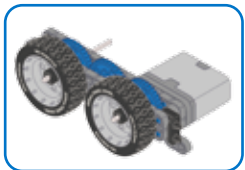

13

4x 228-2500-060
 4x 228-2500-061
 2x 228-2500-128
 2x 228-2500-150
 1x 228-2500-023

QR code: vexiq.com/clawbotiq/13

14

12

White gears reference previous steps
 Weiße Zahnräder verweisen auf vorherige Schritte

6

QR code: vexiq.com/clawbotiq/14

15

8x 228-2500-060
 1x 228-2500-040
 1x 228-2500-026

QR code: vexiq.com/clawbotiq/15

16

4x 228-2500-060
 2x 228-2500-150

QR code: vexiq.com/clawbotiq/16

17

4x
228-2500-060

2x
228-2500-005

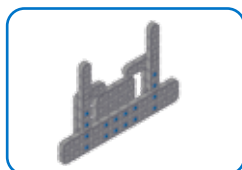
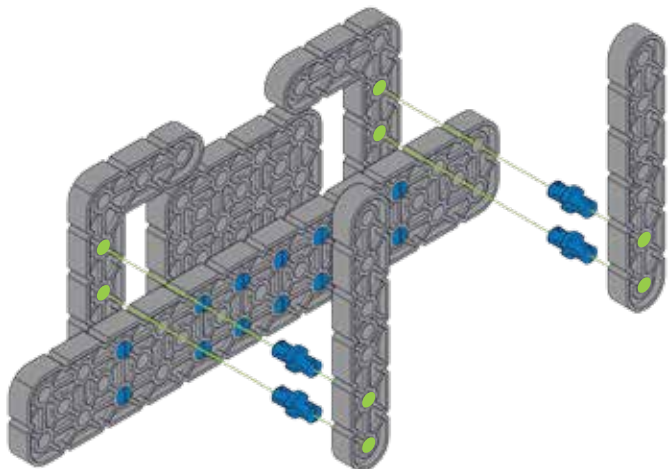

vexiq.com/clawbotiq/17

18

2x
228-2500-060

2x
228-2500-061

1x
228-2540

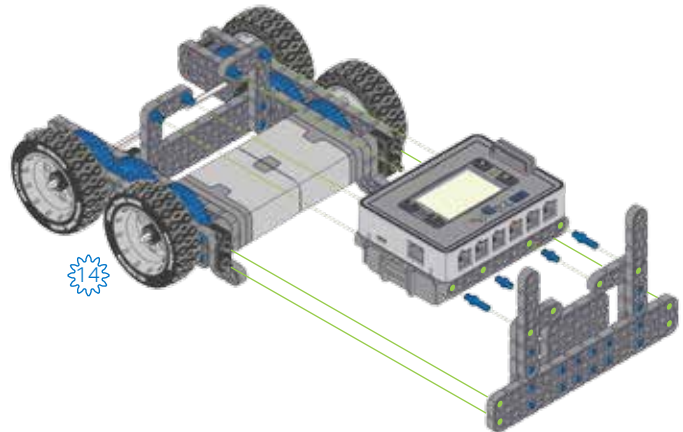
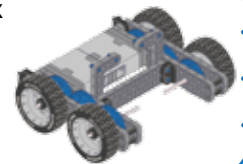

vexiq.com/clawbotiq/18

19

2x
228-2780-001 (200mm)

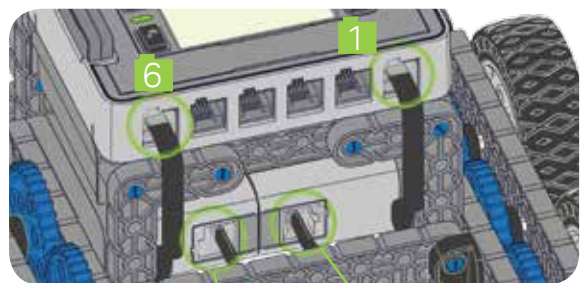

6

1

Connect Smart Device to indicated Robot Brain port
Die Steuerungselemente an den angezeigten Anschluss des Robot Brains anschließen



20

102



Clawbot IQ



Autopilot

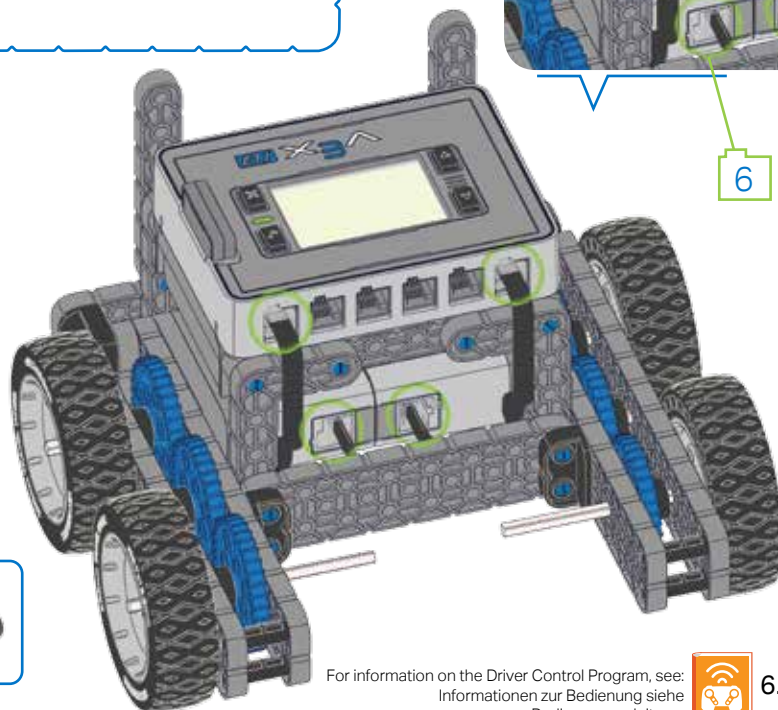

For information on the Driver Control Program, see:
Informationen zur Bedienung siehe Bedienungsanleitung:  6.1

vexiq.com/clawbotiq/19



2 Clawbot IQ

20

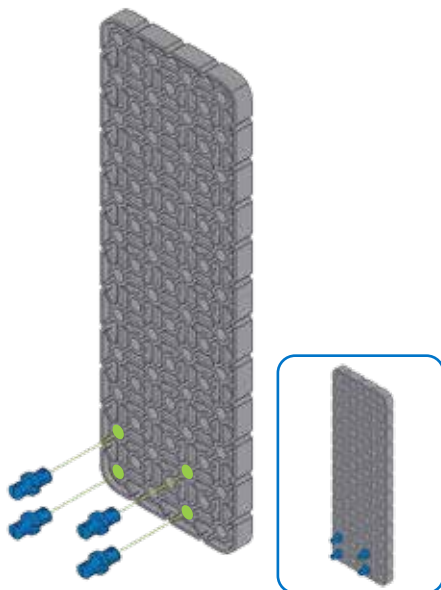
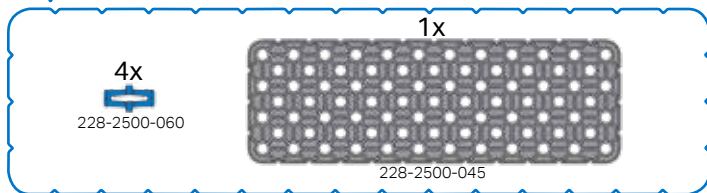

vexiq.com/clawbotiq/20

21

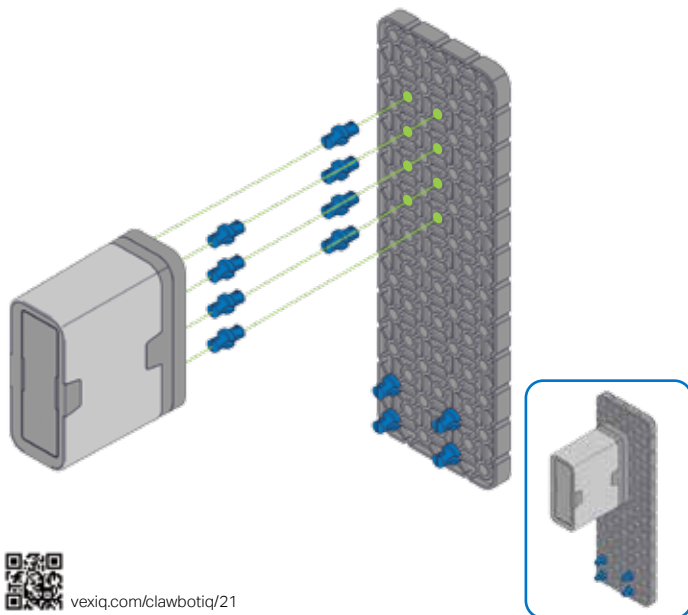
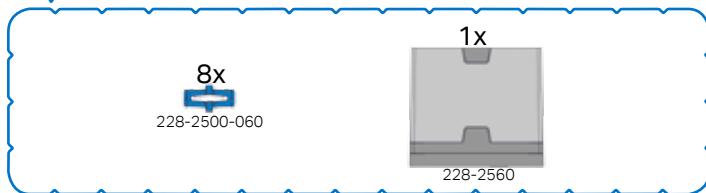

vexiq.com/clawbotiq/21

22

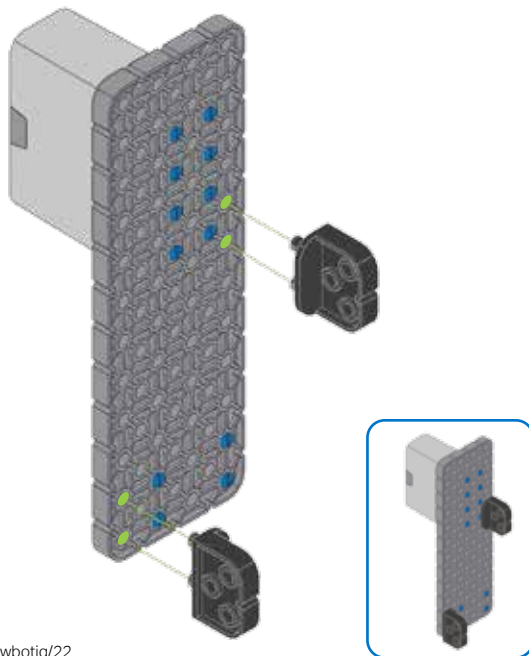
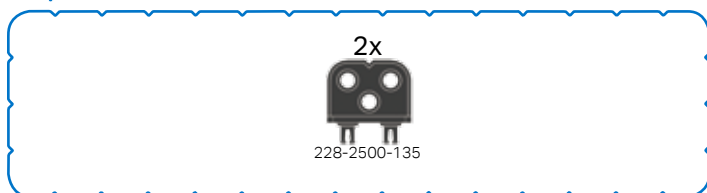

vexiq.com/clawbotiq/22

23

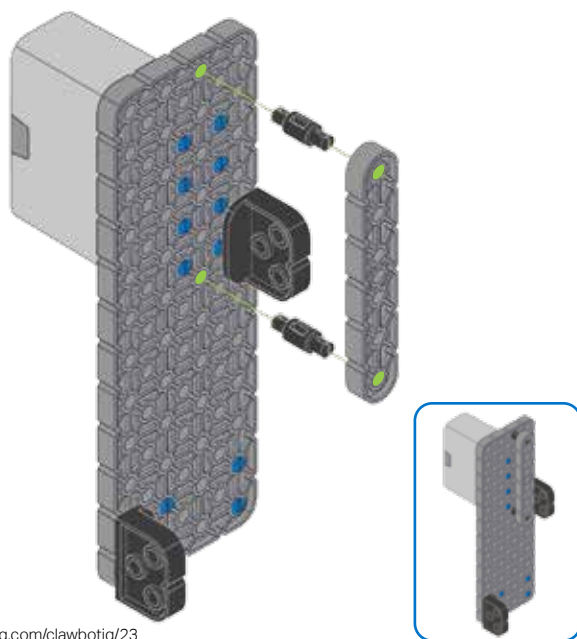
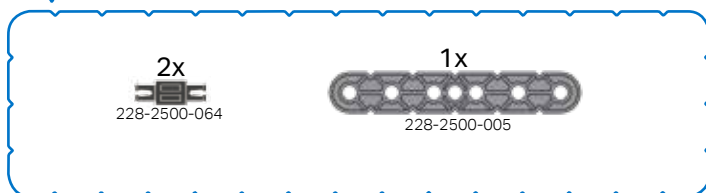

vexiq.com/clawbotiq/23

24

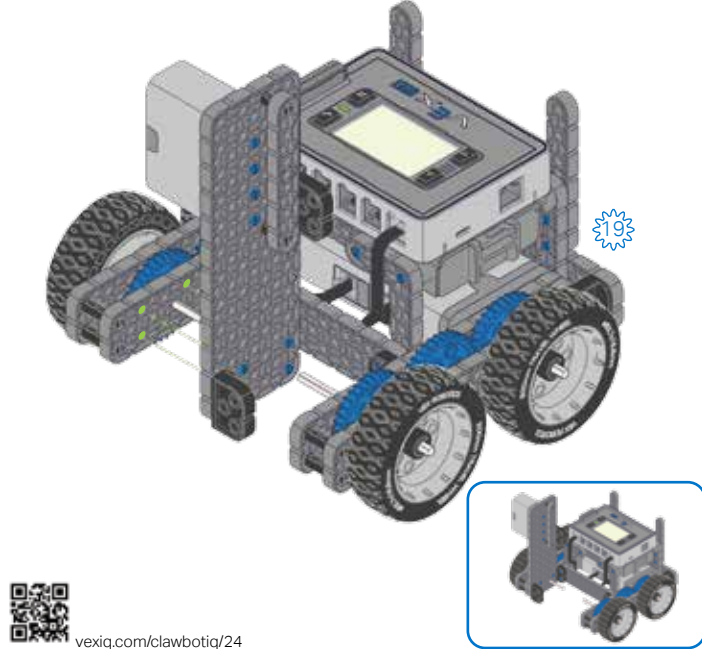
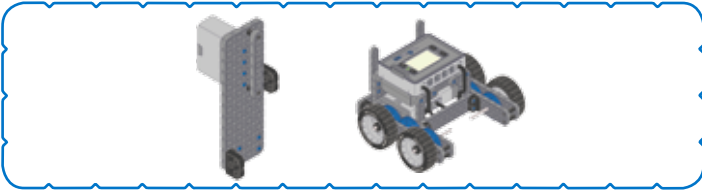

vexiq.com/clawbotiq/24

25

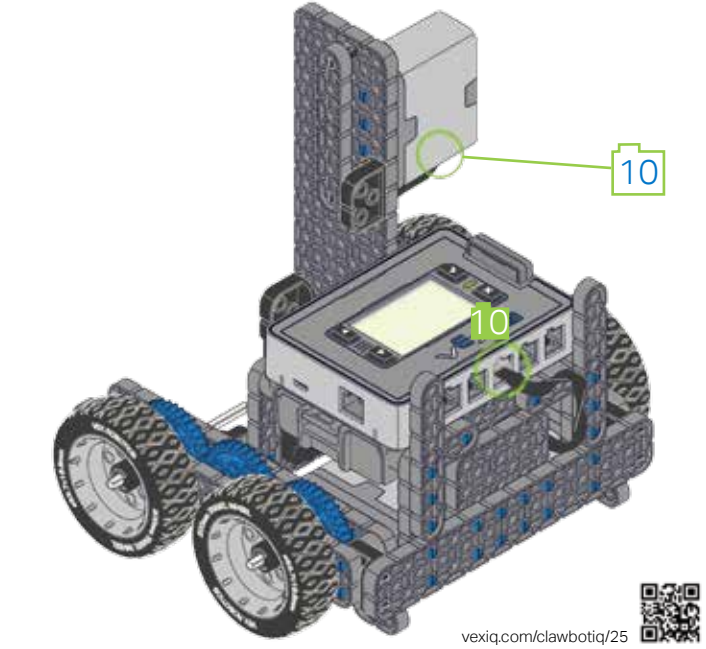
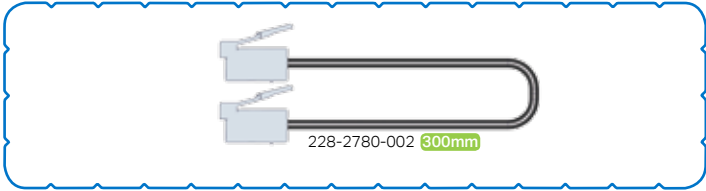

vexiq.com/clawbotiq/25

26

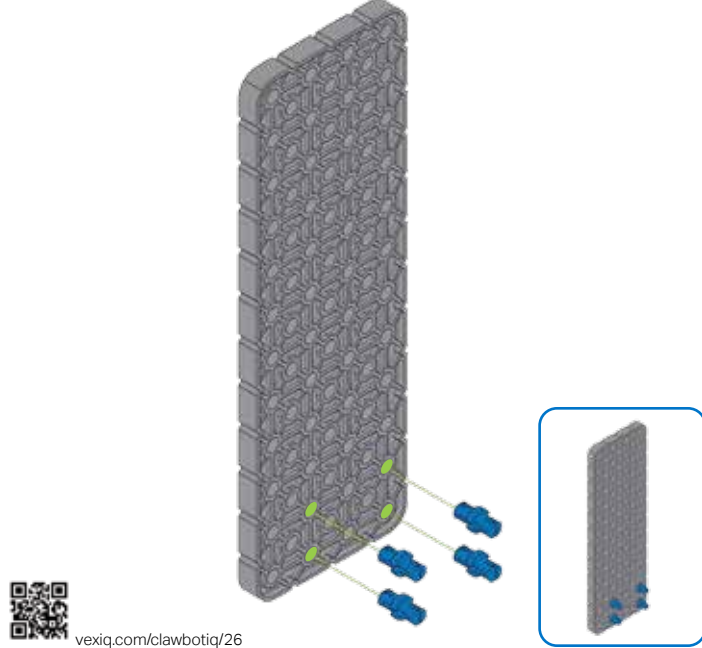
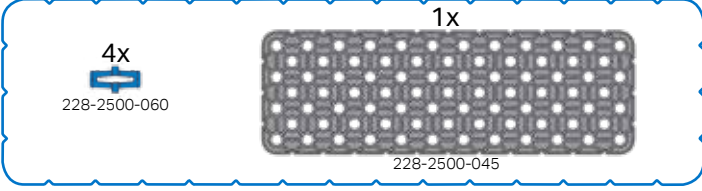

vexiq.com/clawbotiq/26

27

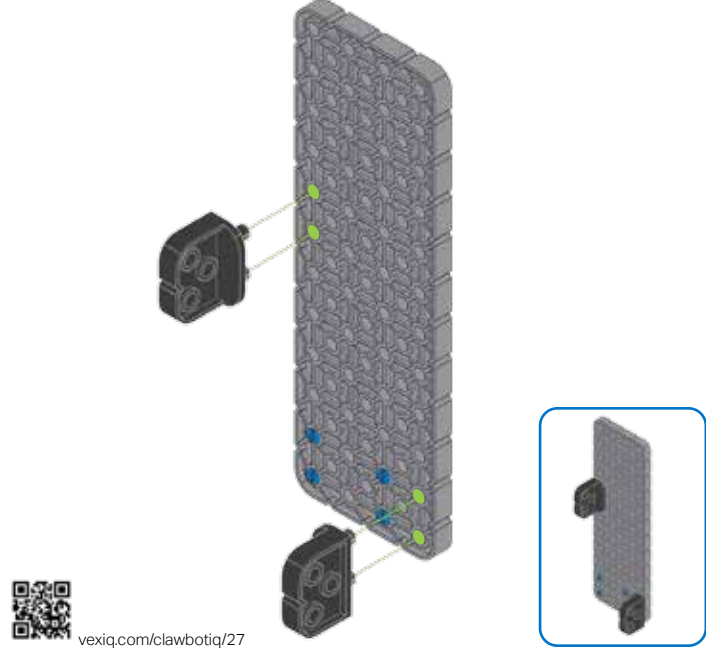
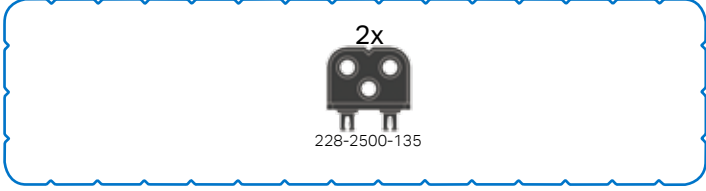

vexiq.com/clawbotiq/27

28

2x
228-2500-064

1x
228-2500-005

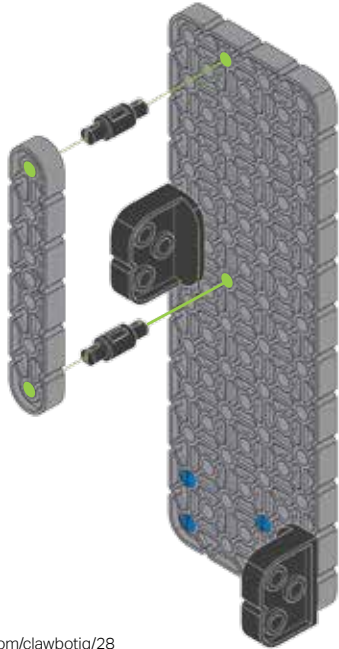

vexiq.com/clawbotiq/28

29

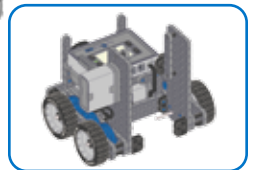
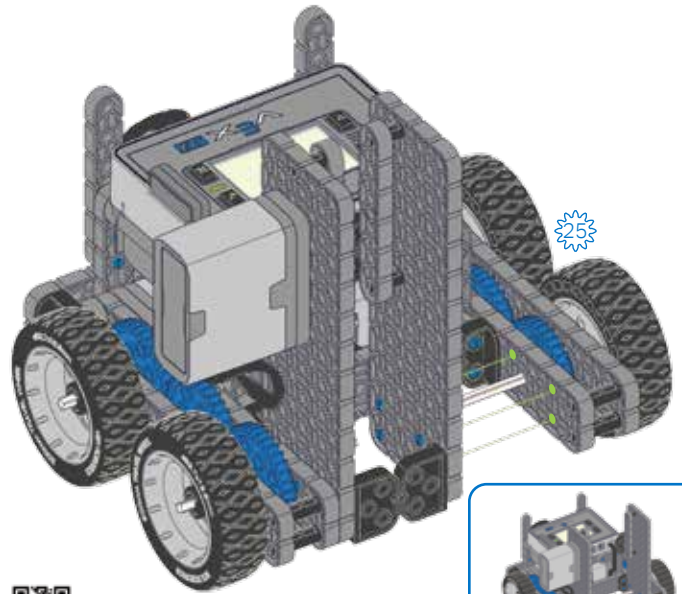

vexiq.com/clawbotiq/29

30

4x
228-2500-062

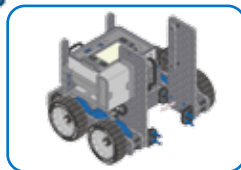
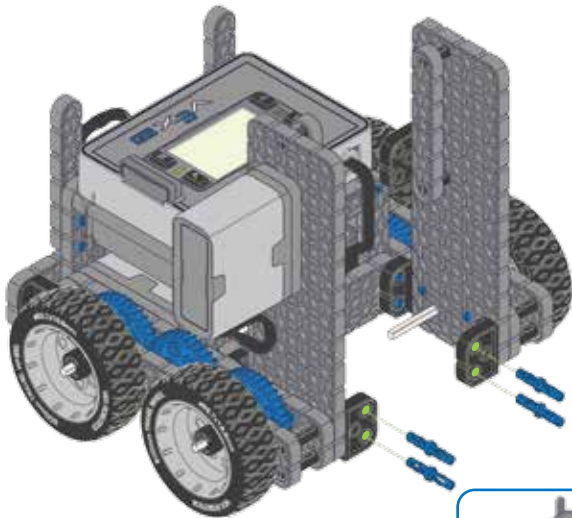

vexiq.com/clawbotiq/30

31

1x
228-2500-021

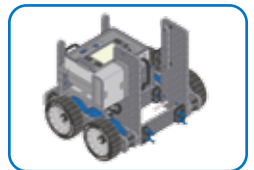
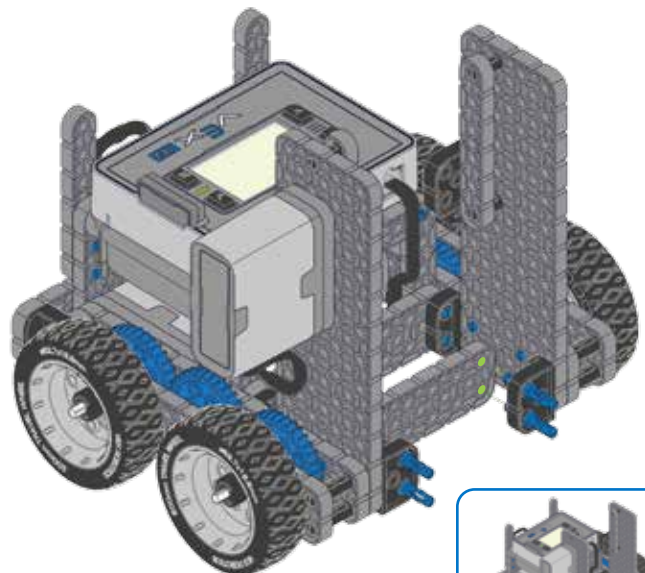

vexiq.com/clawbotiq/31

32

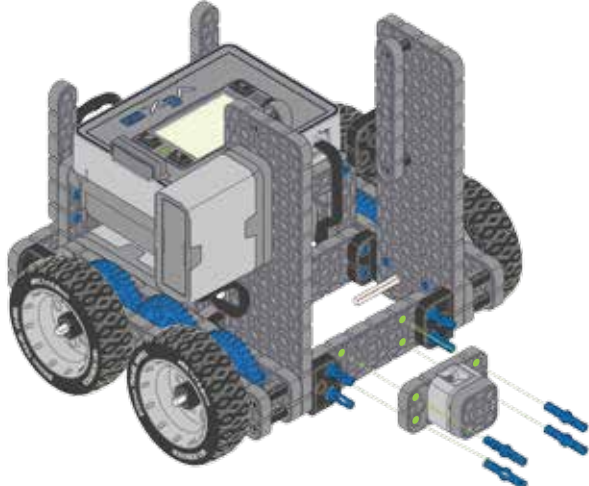
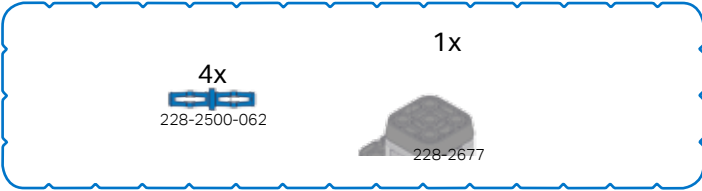

vexiq.com/clawbotiq/32

33

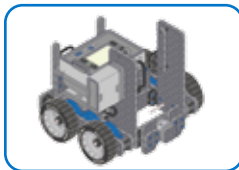
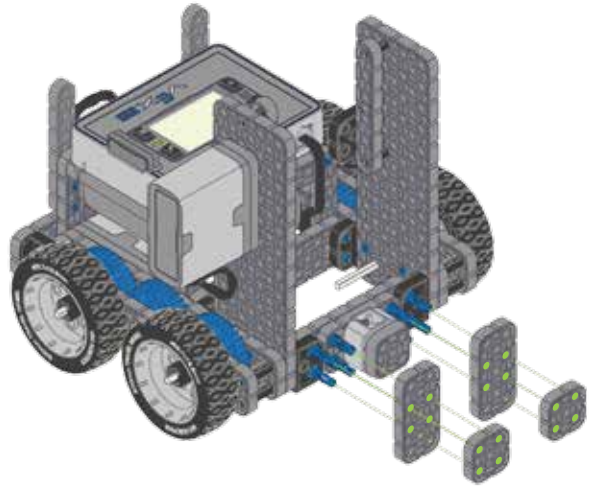
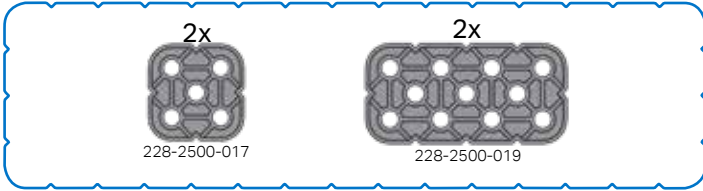

vexiq.com/clawbotiq/33

34

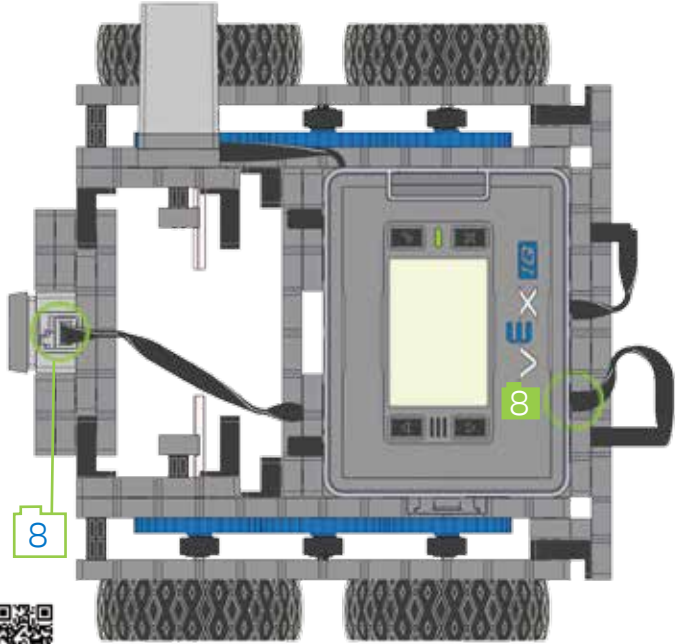
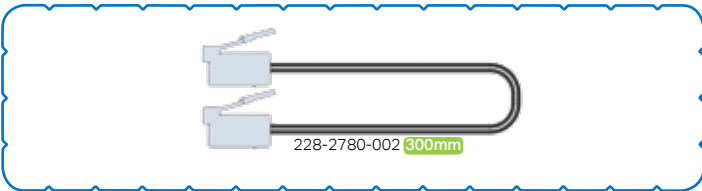

vexiq.com/clawbotiq/34

35

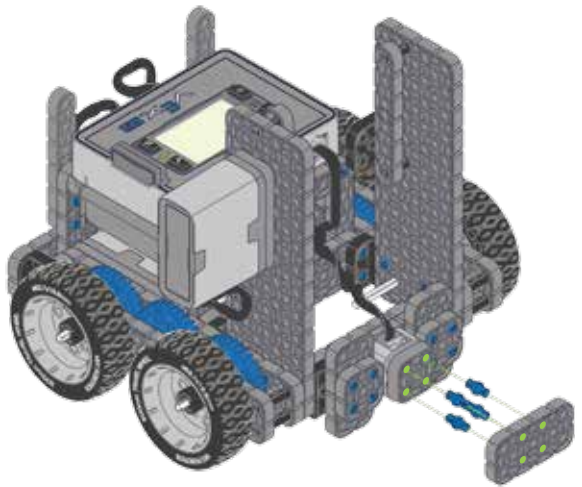
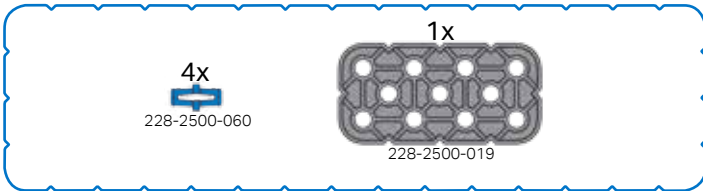

vexiq.com/clawbotiq/35

36

2x 228-250-143 2x 228-2500-213 1x 228-2500-124 (8xP)

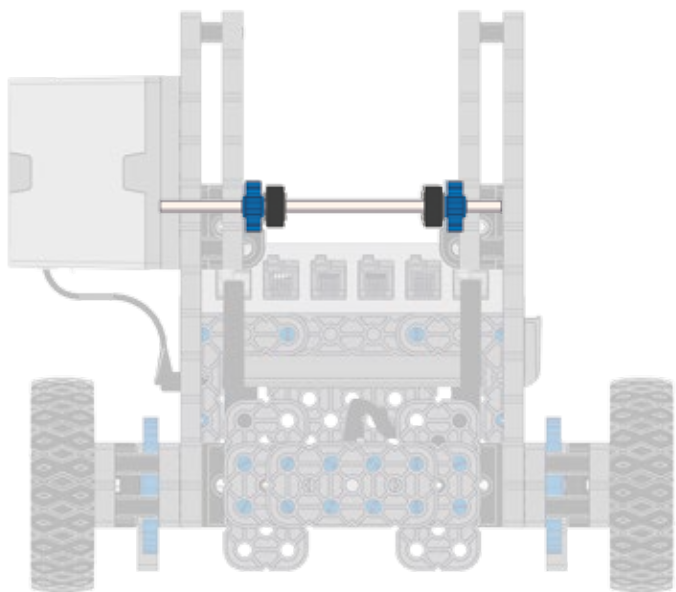
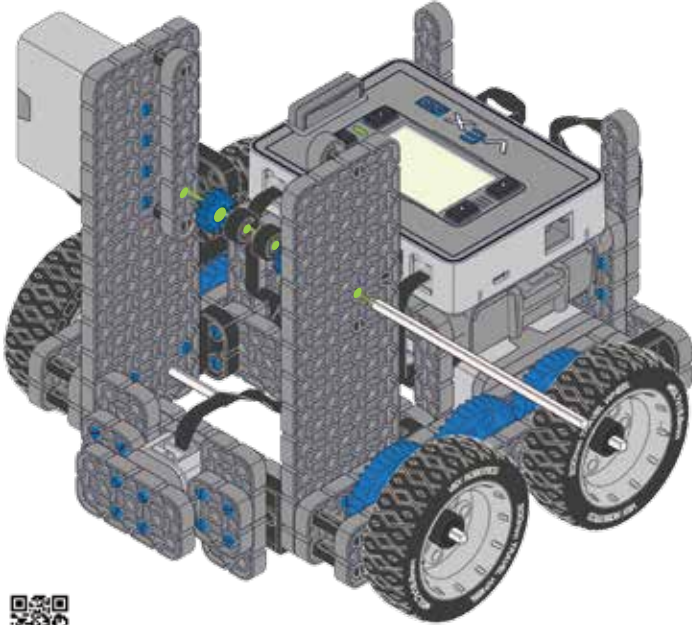

vexiq.com/clawbotiq/36

1:1

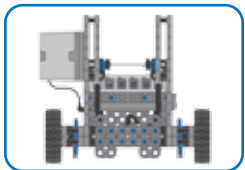

37

6x 228-2500-060 1x 228-2500-023

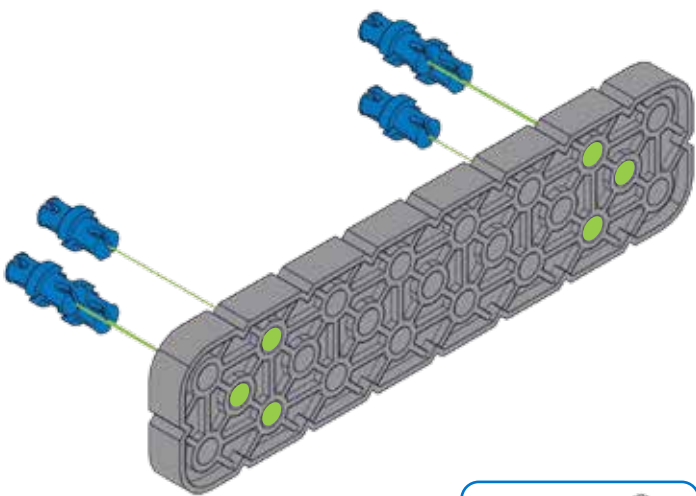

vexiq.com/clawbotiq/37

38

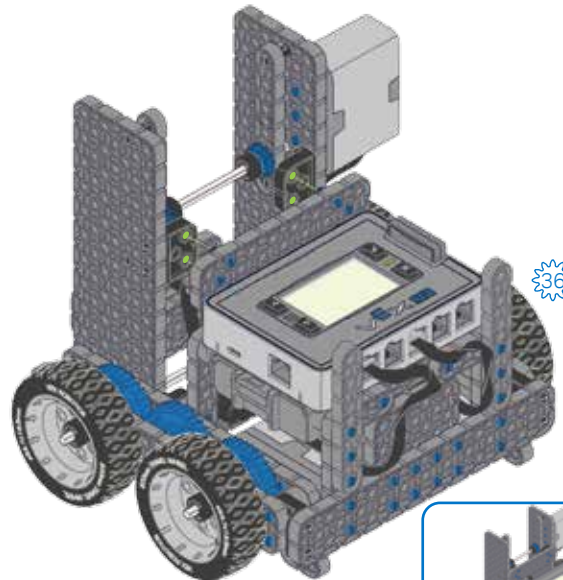

vexiq.com/clawbotiq/38



39

4x
228-2500-060

1x
228-2500-011

1x
228-2500-009

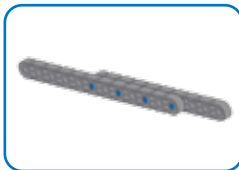
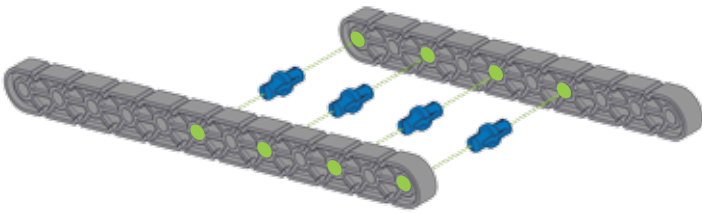

vexiq.com/clawbotiq/39

40

2x
228-2500-062

2x
228-2500-170

2x
228-2500-067

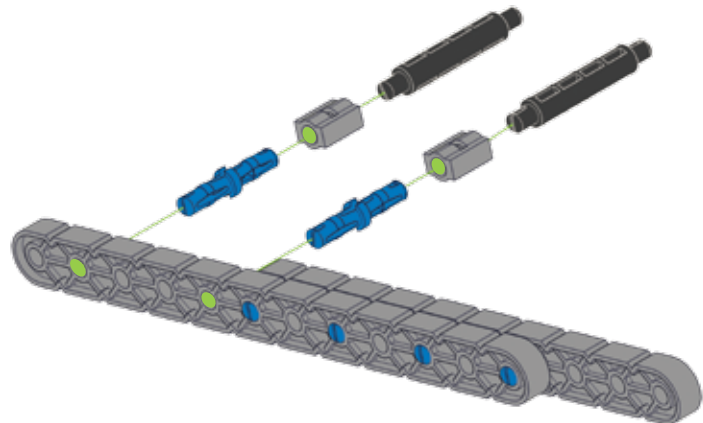

vexiq.com/clawbotiq/40

41

2x
228-2500-007

1x
228-2500-070

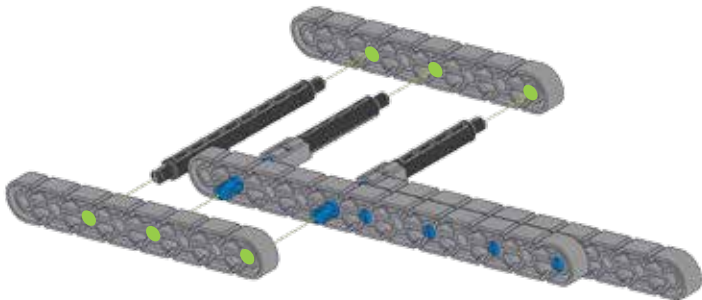

vexiq.com/clawbotiq/41

42

4x
228-2500-060



vexiq.com/clawbotiq/42

43

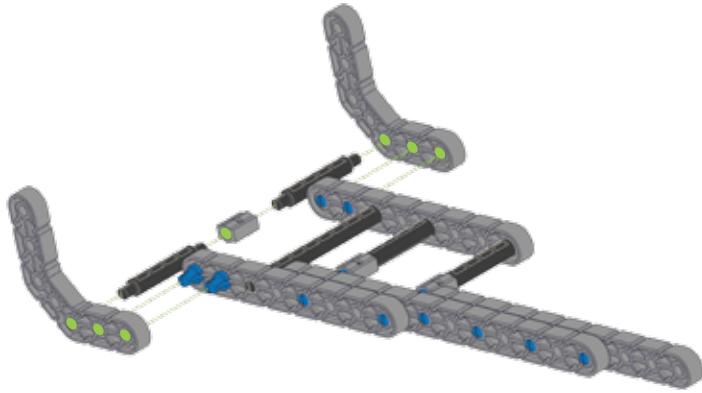
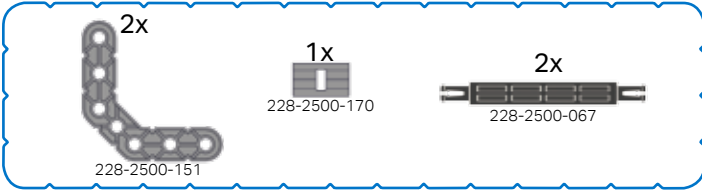

vexiq.com/clawbotiq/43

44

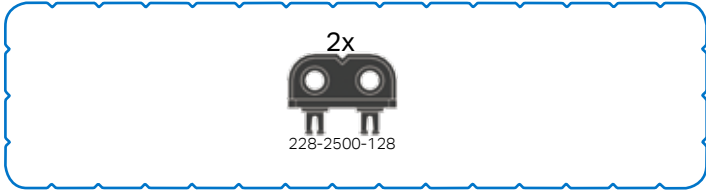

vexiq.com/clawbotiq/44

45

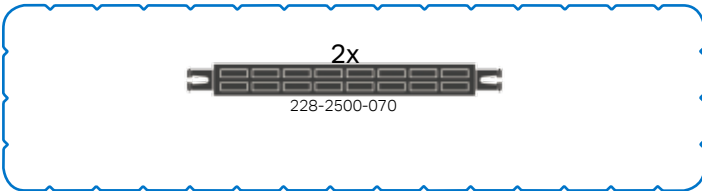

vexiq.com/clawbotiq/45

46

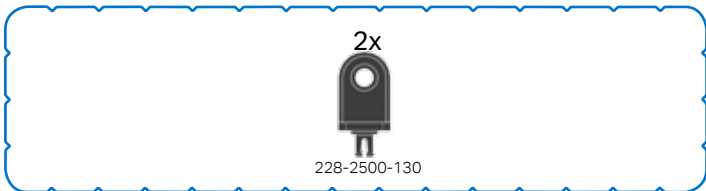

vexiq.com/clawbotiq/46

47

2x
228-2500-060



vexiq.com/clawbotiq/47

48

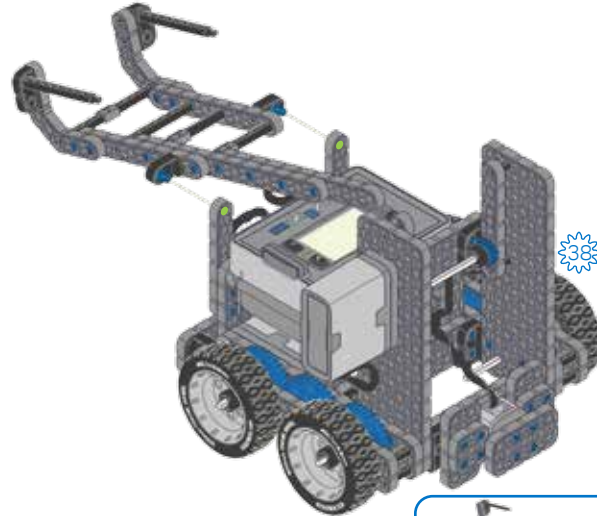

vexiq.com/clawbotiq/48

49

4x 228-2500-061
1x 228-2500-040
2x 228-2500-144

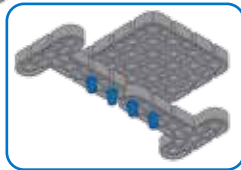
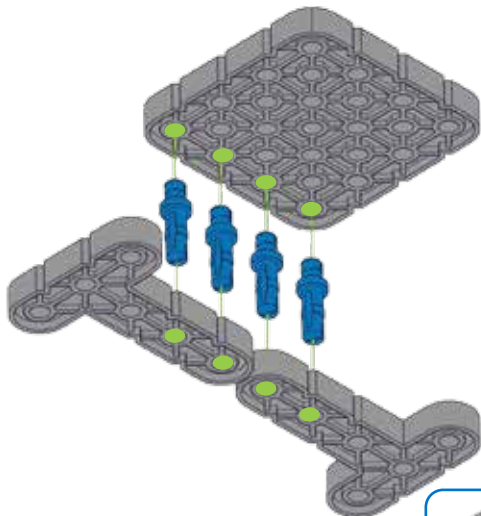

vexiq.com/clawbotiq/49

50

4x 228-2500-064
1x 228-2500-019

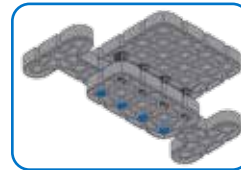
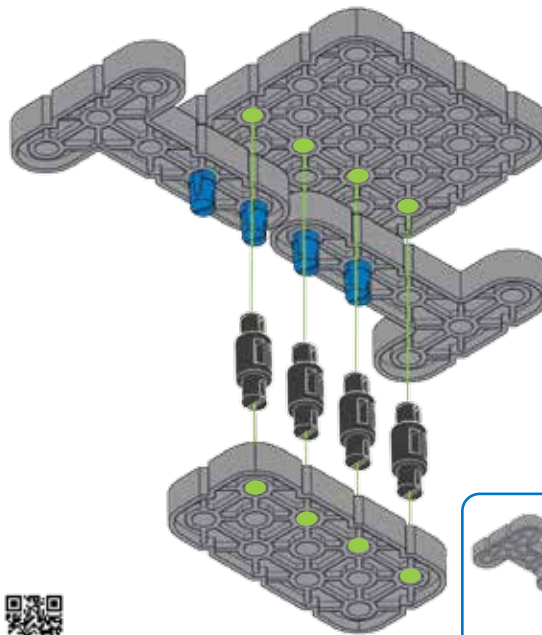

vexiq.com/clawbotiq/50

51

1x
228-2500-061

2x
228-2500-062

1x
228-2500-064

1x
228-2500-002

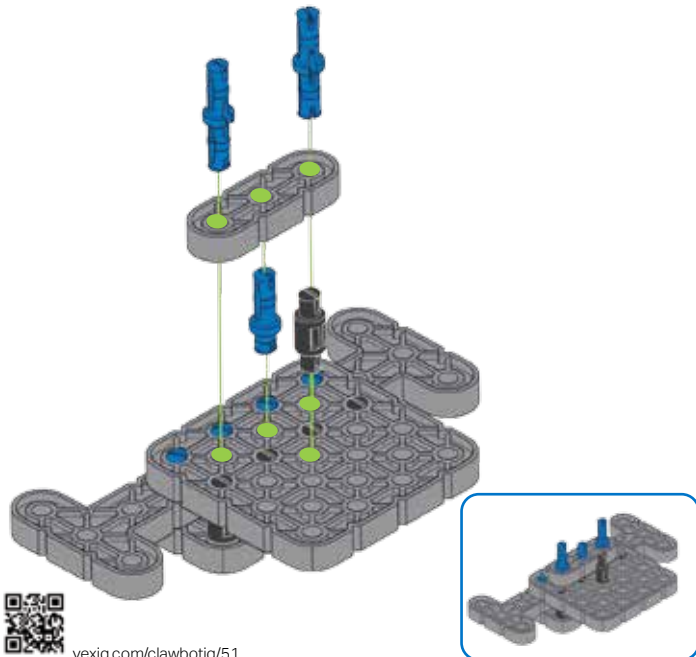

vexiq.com/clawbotiq/51

52

2x
228-2500-214

2x
228-2500-076 4xP

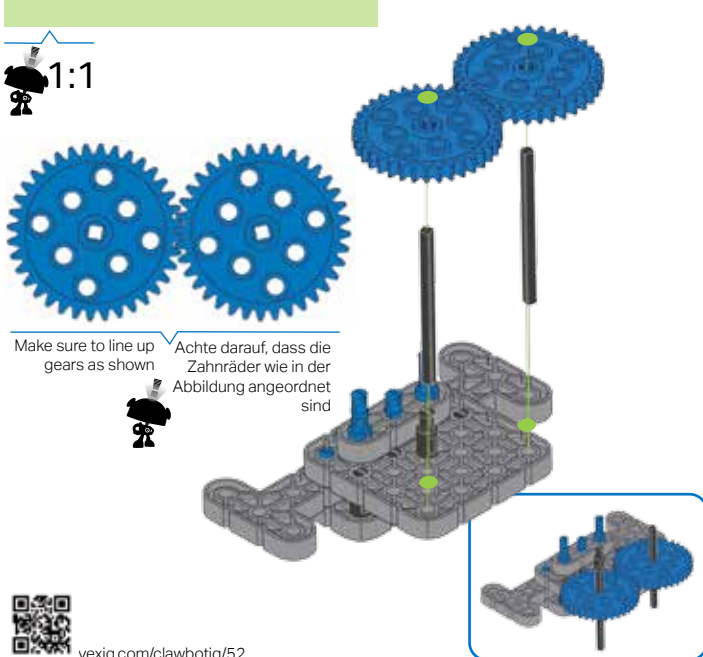

vexiq.com/clawbotiq/52

53

1x
228-2500-040

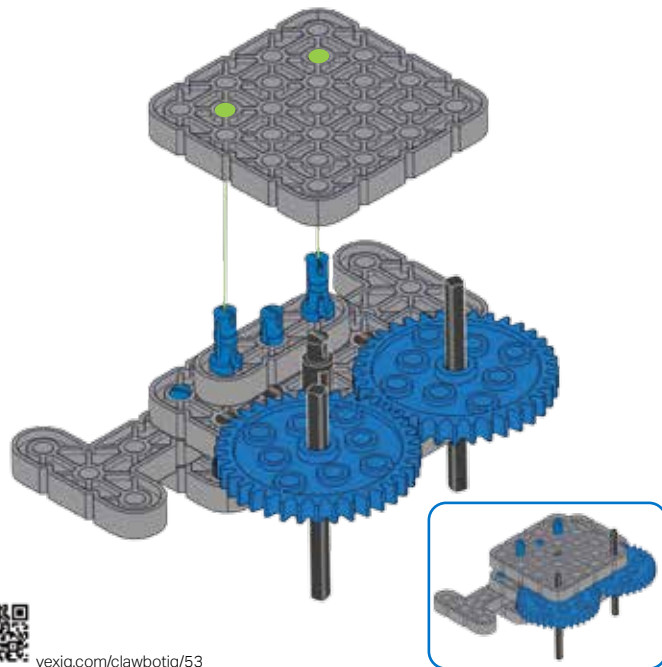

vexiq.com/clawbotiq/53

54

2x
228-2500-143

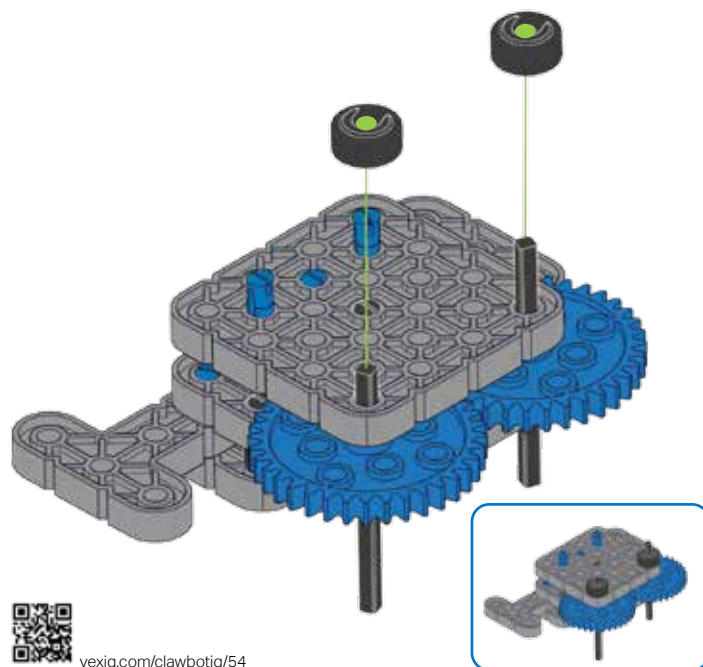

vexiq.com/clawbotiq/54

55

4x
228-2500-061

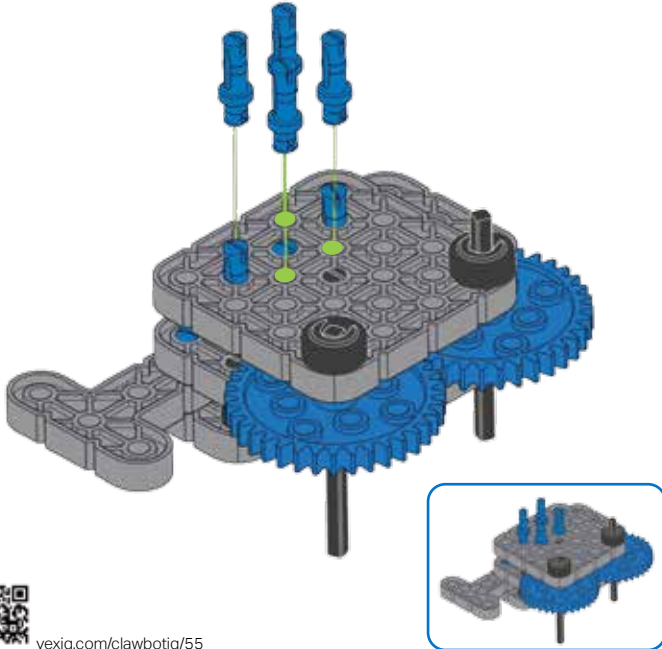

vexiq.com/clawbotiq/55

56

4x 228-2500-060
2x 228-2500-134

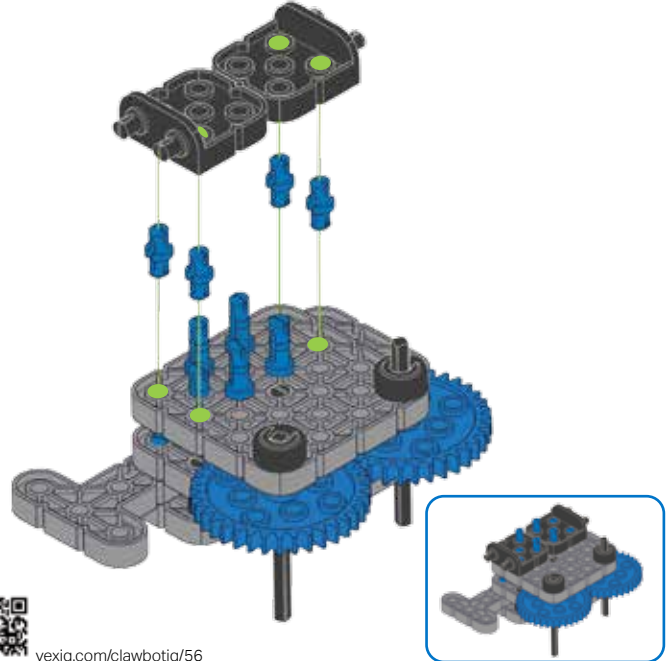

vexiq.com/clawbotiq/56

57

1x
228-2500-017

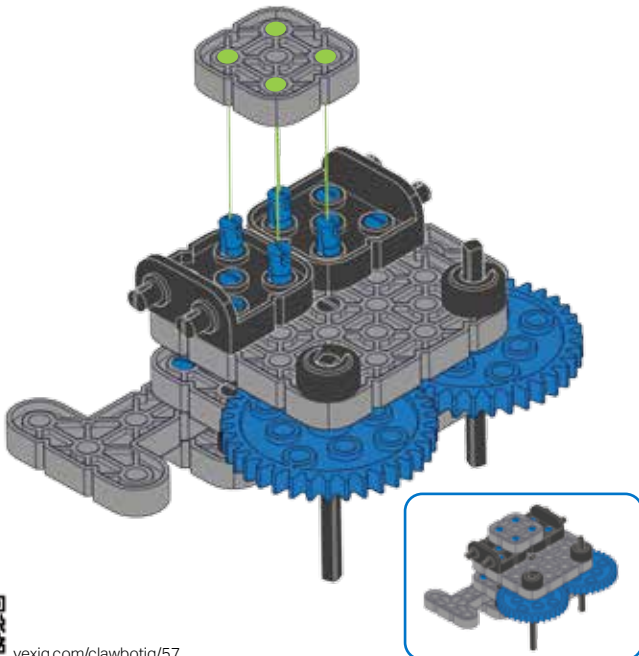

vexiq.com/clawbotiq/57

58

2x
228-2500-149 (60°)

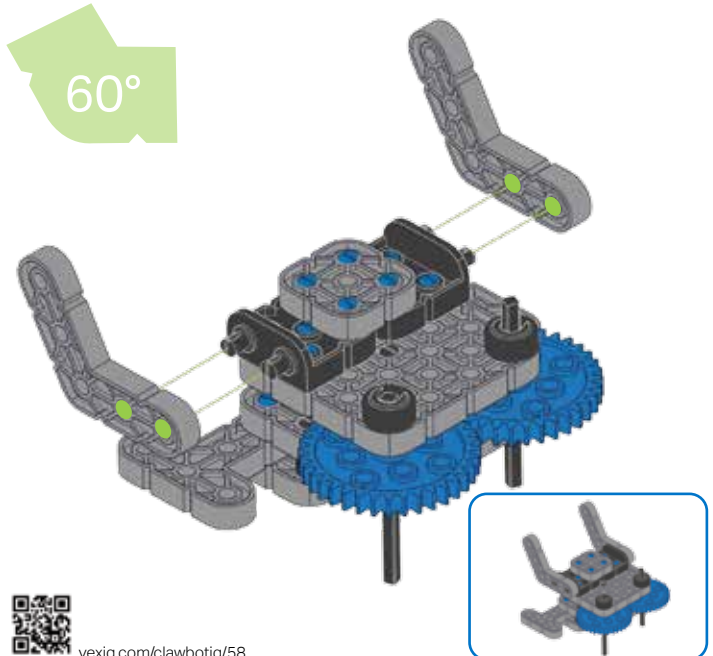

vexiq.com/clawbotiq/58

59

4x
228-2500-061

2x
228-2500-003

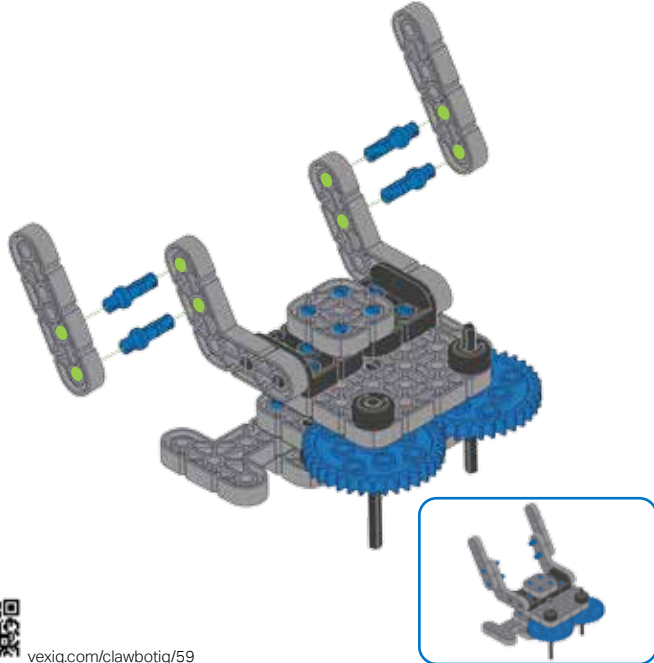

 vexiq.com/clawbotiq/59

60

4x
228-2500-061

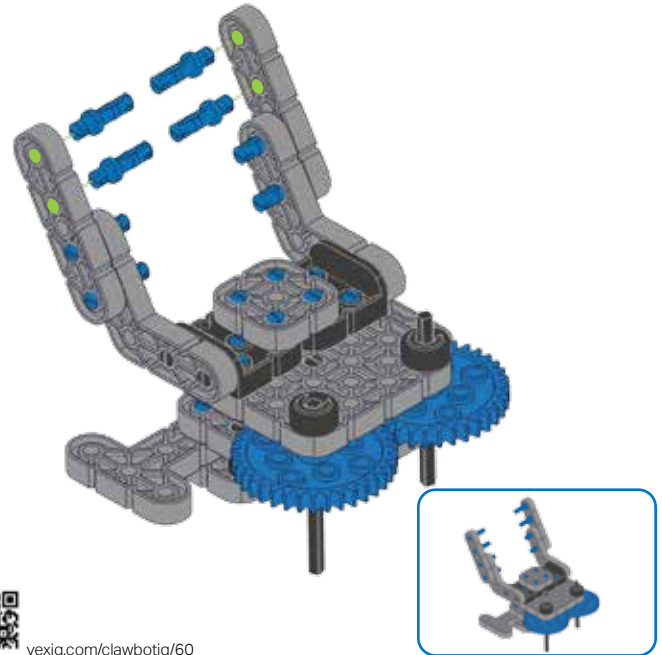

 vexiq.com/clawbotiq/60

61

2x
228-2500-157

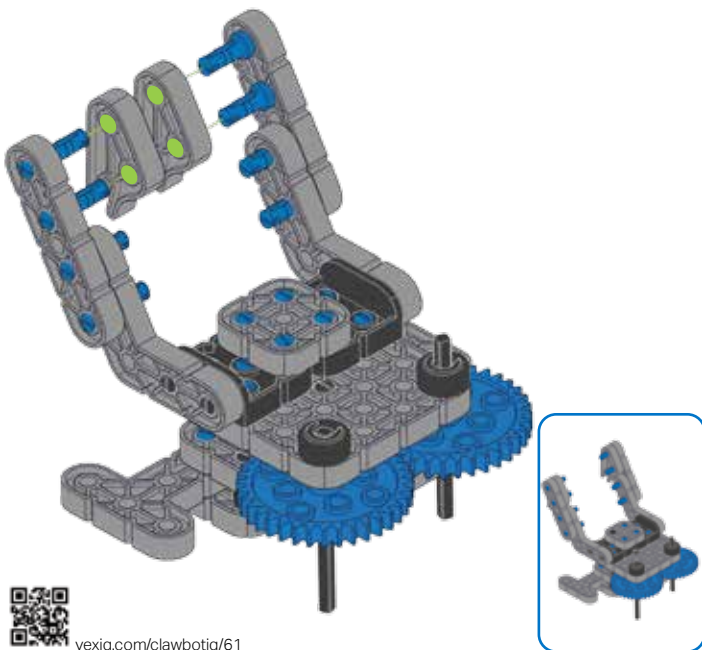

 vexiq.com/clawbotiq/61

62

2x
228-2500-009

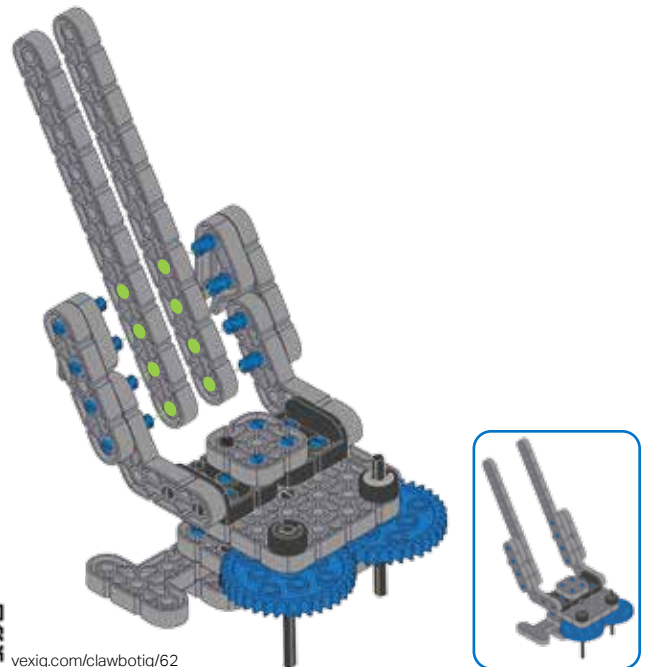

 vexiq.com/clawbotiq/62

63

4x
228-2500-060

2x
228-2500-215

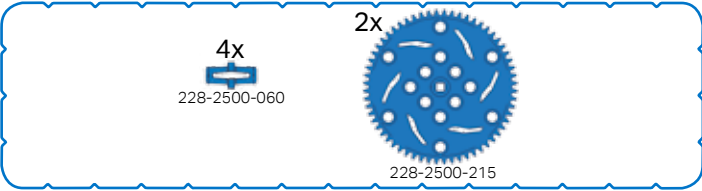
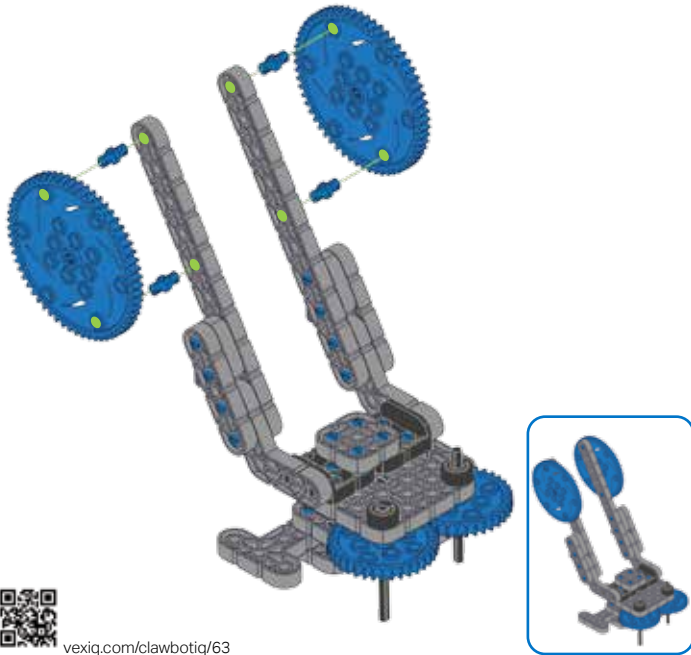
vexiq.com/clawbotiq/63

64

3x
228-2500-064

vexiq.com/clawbotiq/64

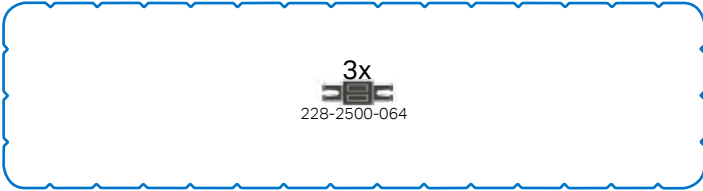
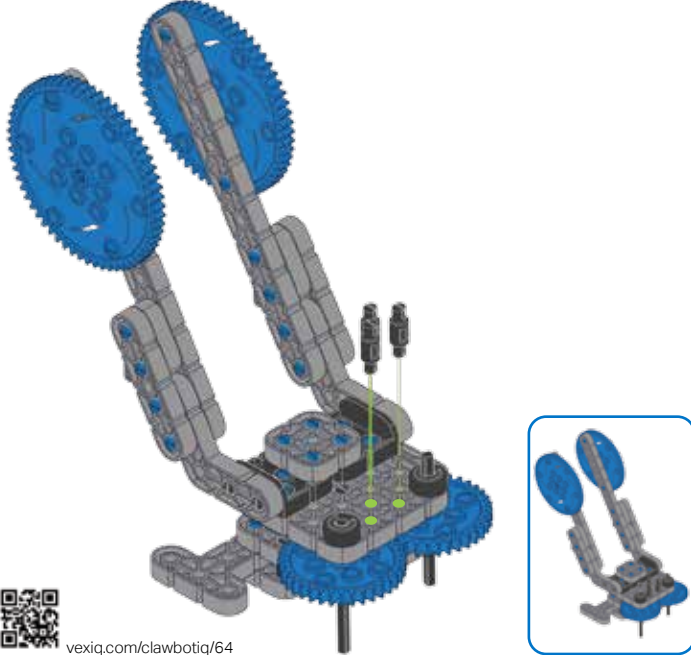
65

1x
228-2560

vexiq.com/clawbotiq/65

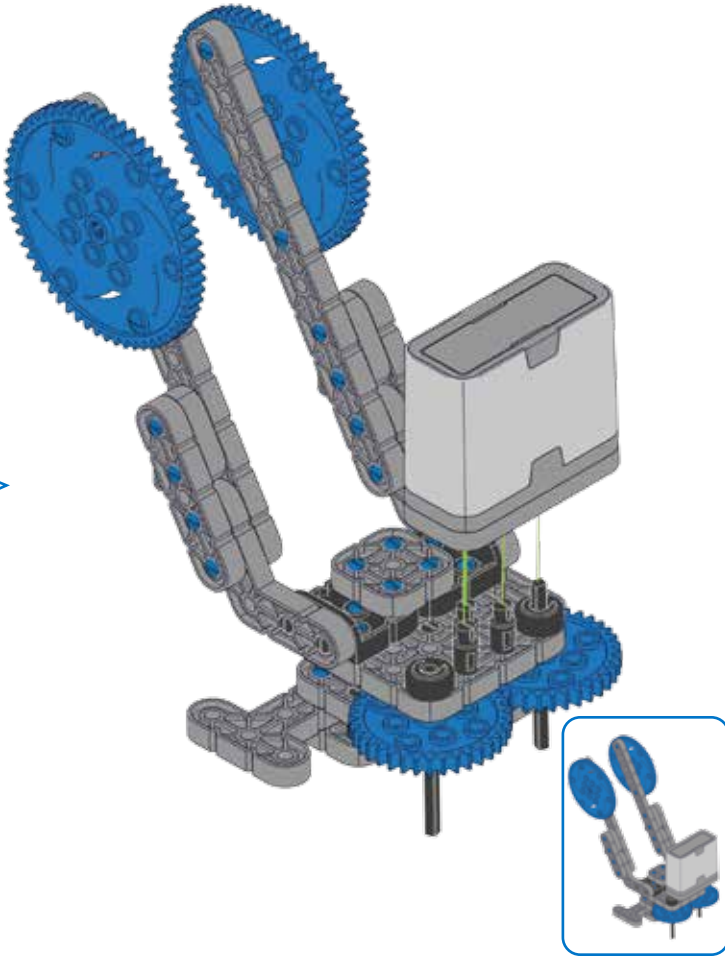
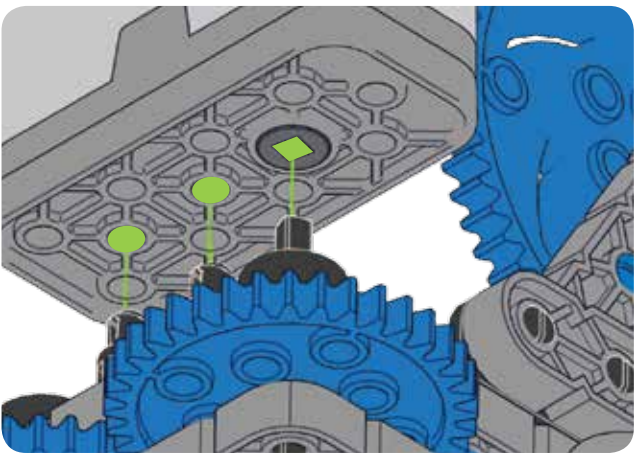
66

1x 228-2500-148 45°

2x 228-2500-060

1x 228-2500-141

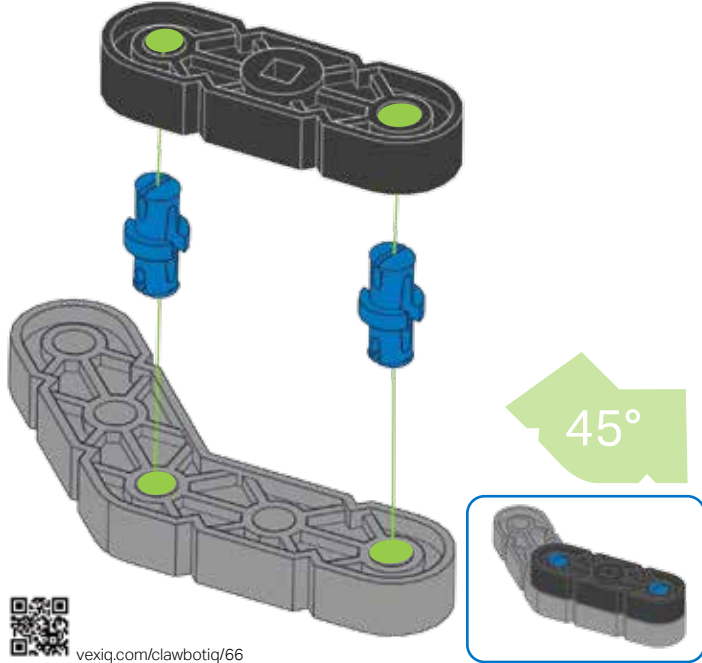

67

1x 228-2500-145

2x 228-2500-061

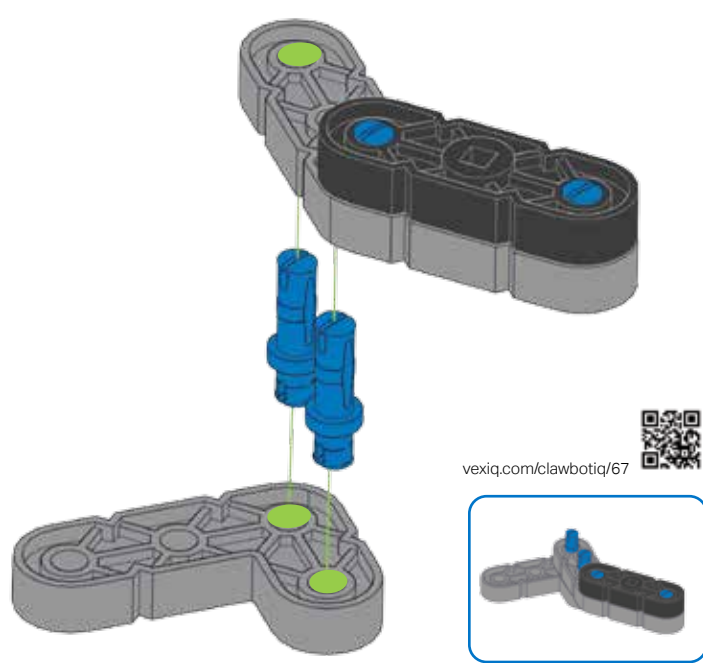

68

2x 228-2500-061

1x 228-2500-005

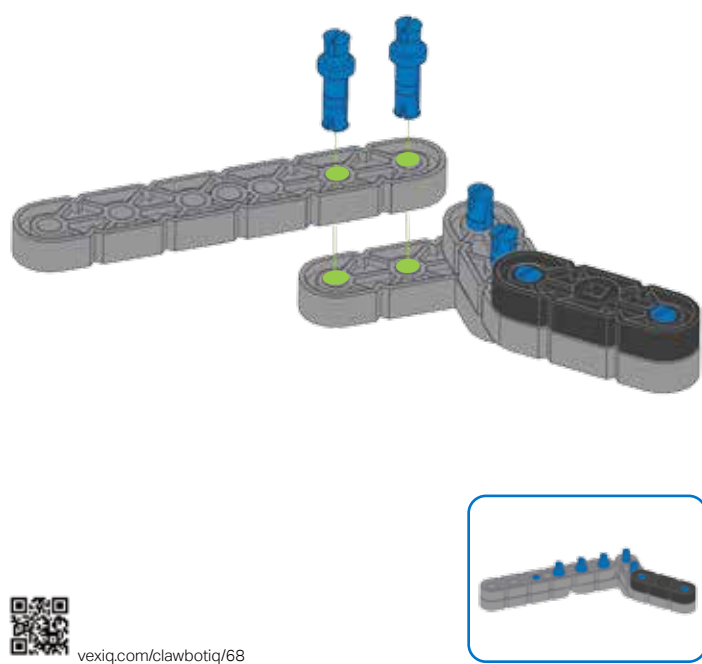

69

1x 228-2500-060

1x 228-2500-061

1x 228-2500-003

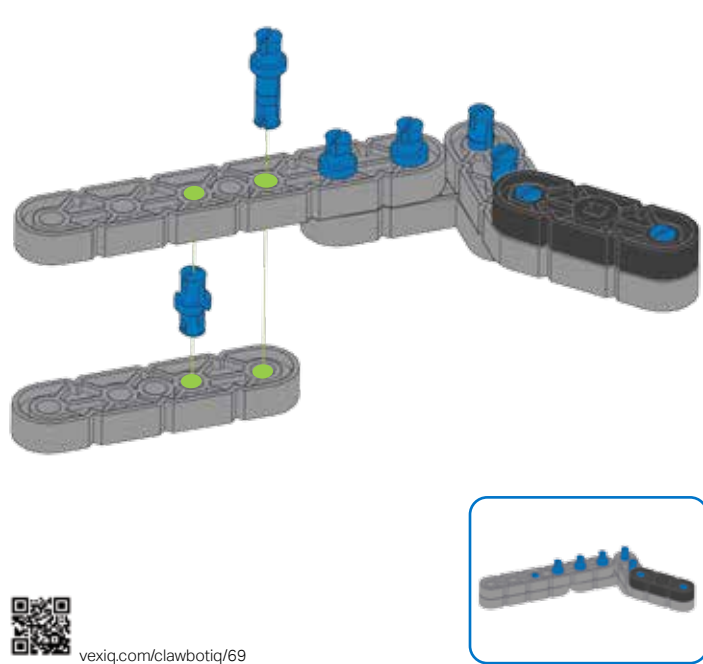

70

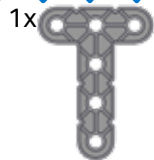

228-2500-144

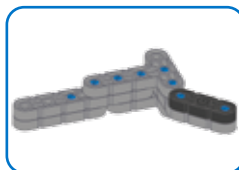
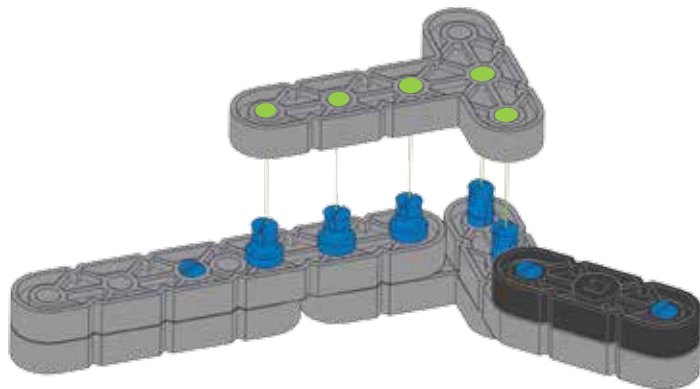

vexiq.com/clawbotiq/70

71

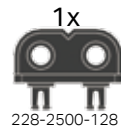

228-2500-128

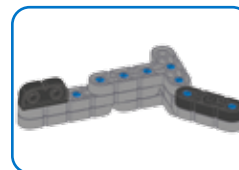
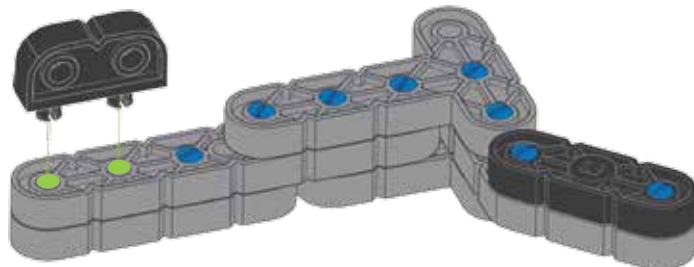

vexiq.com/clawbotiq/71

72

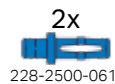

228-2500-061

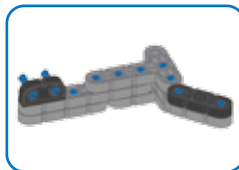
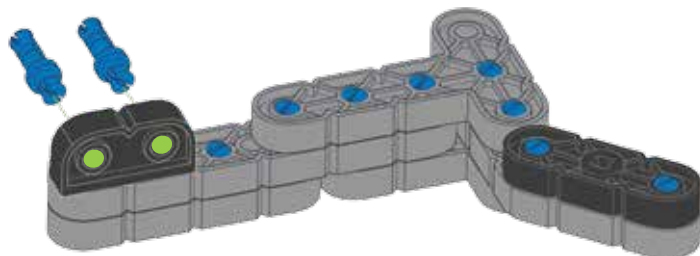

vexiq.com/clawbotiq/72

73



228-2500-207

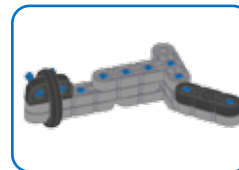

vexiq.com/clawbotiq/73

74

1x
228-2500-060

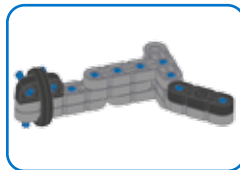
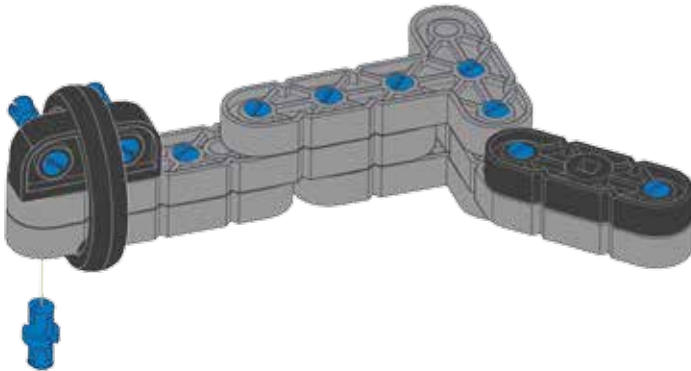

vexiq.com/clawbotiq/74

75

1x
228-2500-143

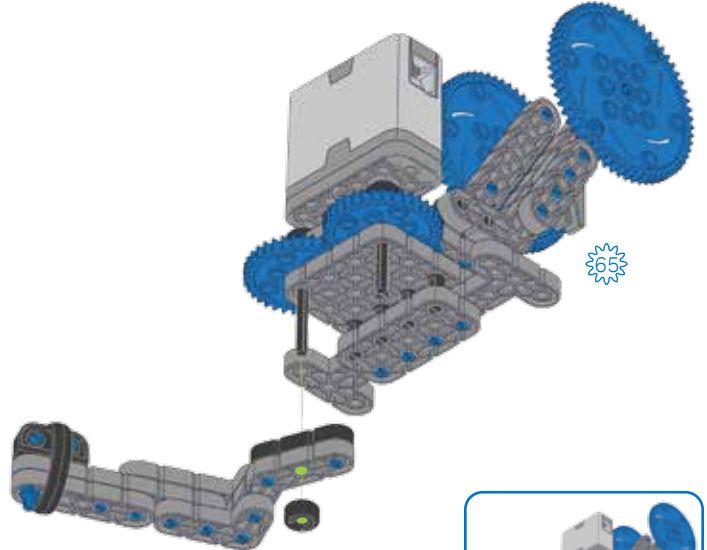

vexiq.com/clawbotiq/75

76

1x
228-2500-148 45°

2x
228-2500-060

1x
228-2500-141

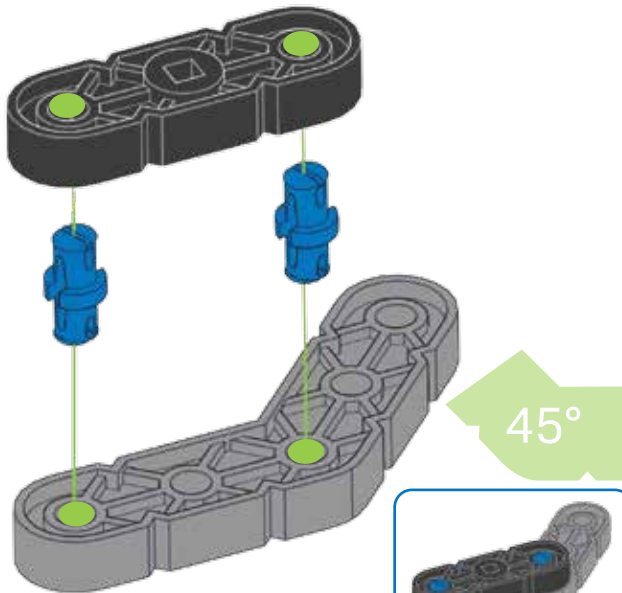

vexiq.com/clawbotiq/76

77

1x
228-2500-145

2x
228-2500-061

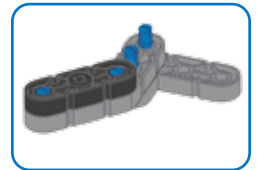
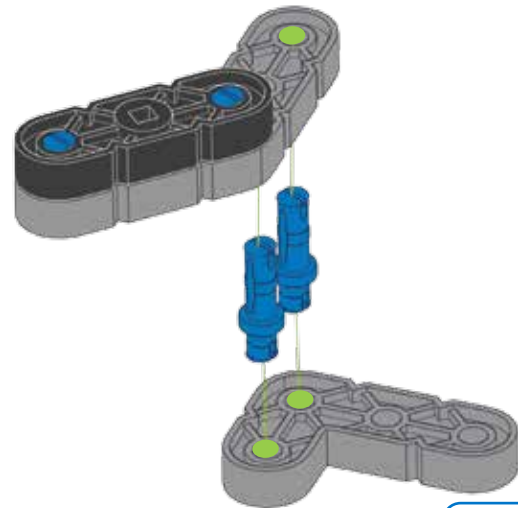

vexiq.com/clawbotiq/77

78

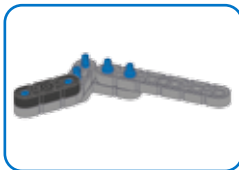
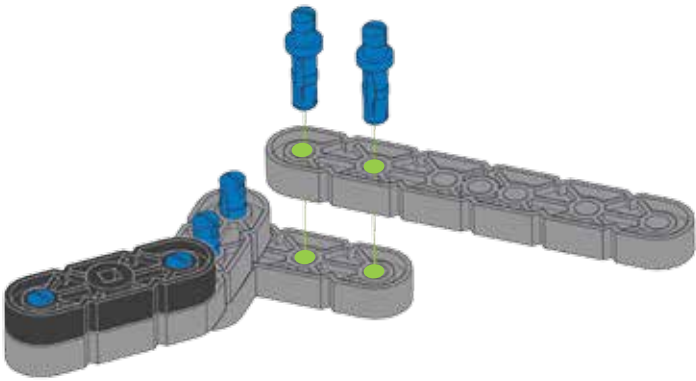
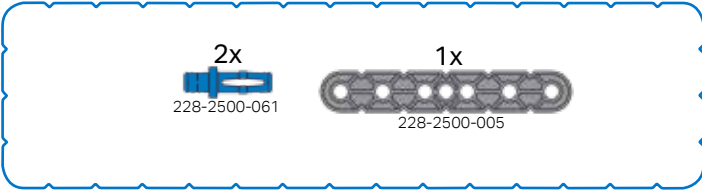

79

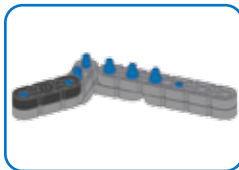
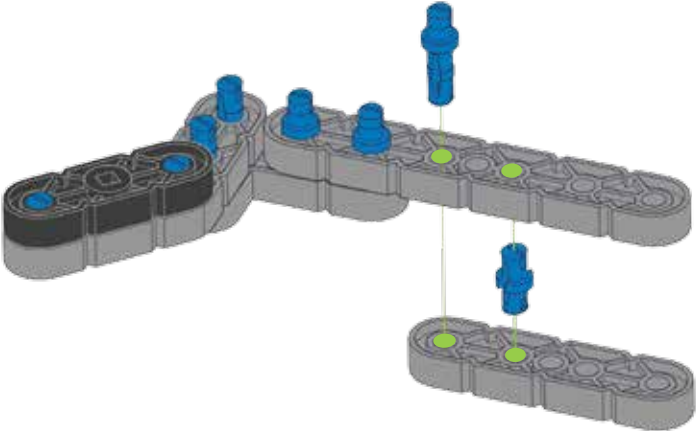
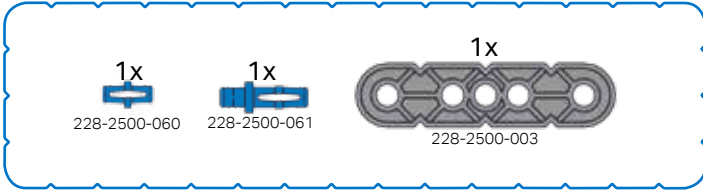

80

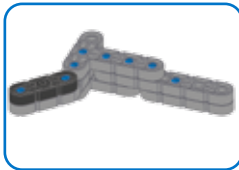
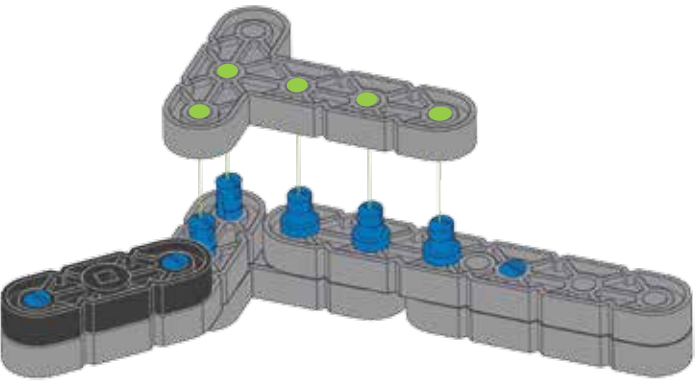
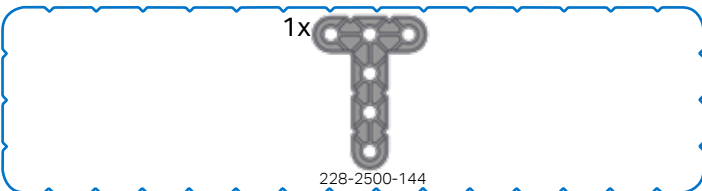

81

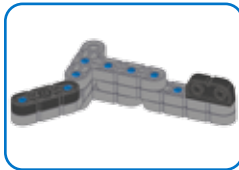
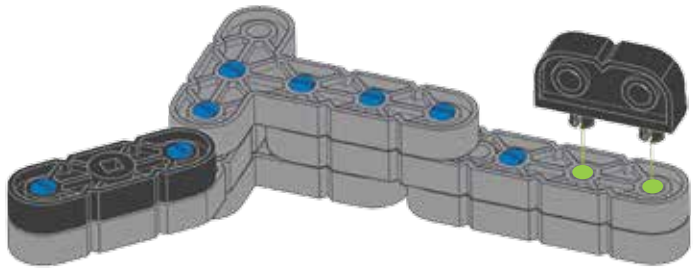
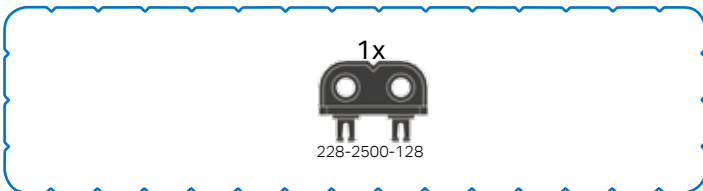

82

2x
228-2500-061

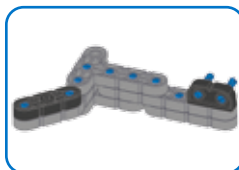
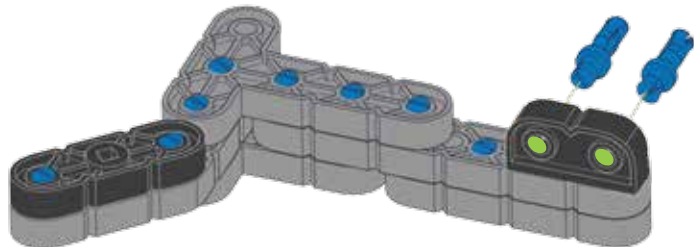

vexiq.com/clawbotiq/82

83

1x
228-2500-207

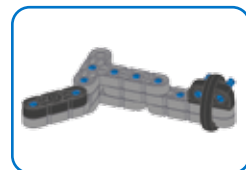
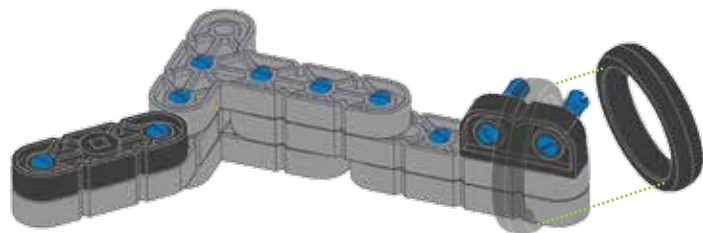

vexiq.com/clawbotiq/83

84

1x
228-2500-060

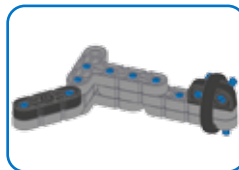
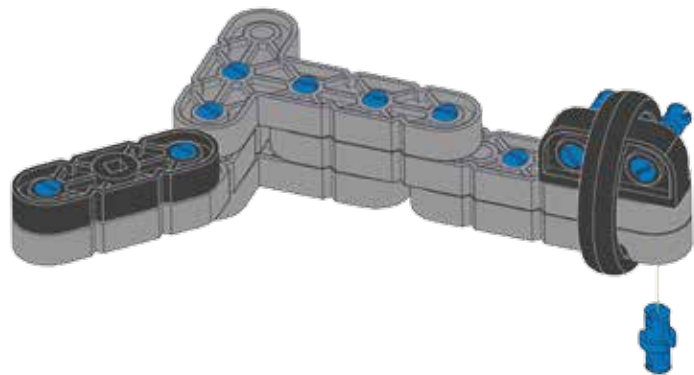

vexiq.com/clawbotiq/84

85

1x
228-2500-143

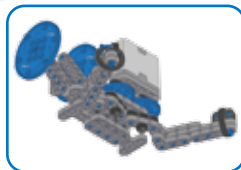
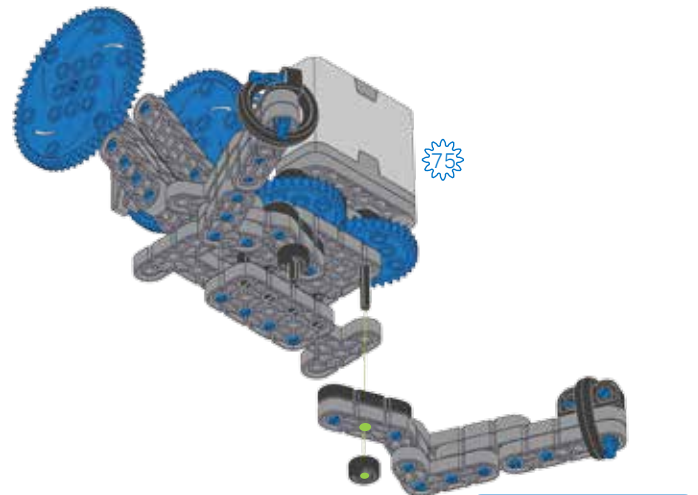
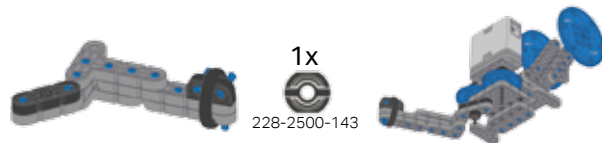

vexiq.com/clawbotiq/85

86

2x  228-2500-143

1x  228-2500-124 8xP

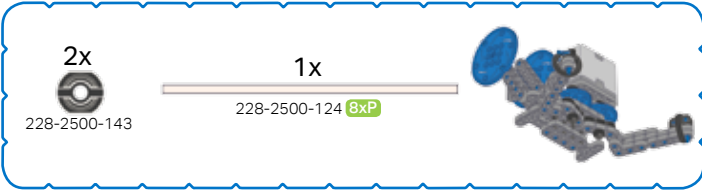
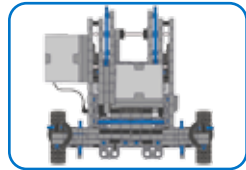
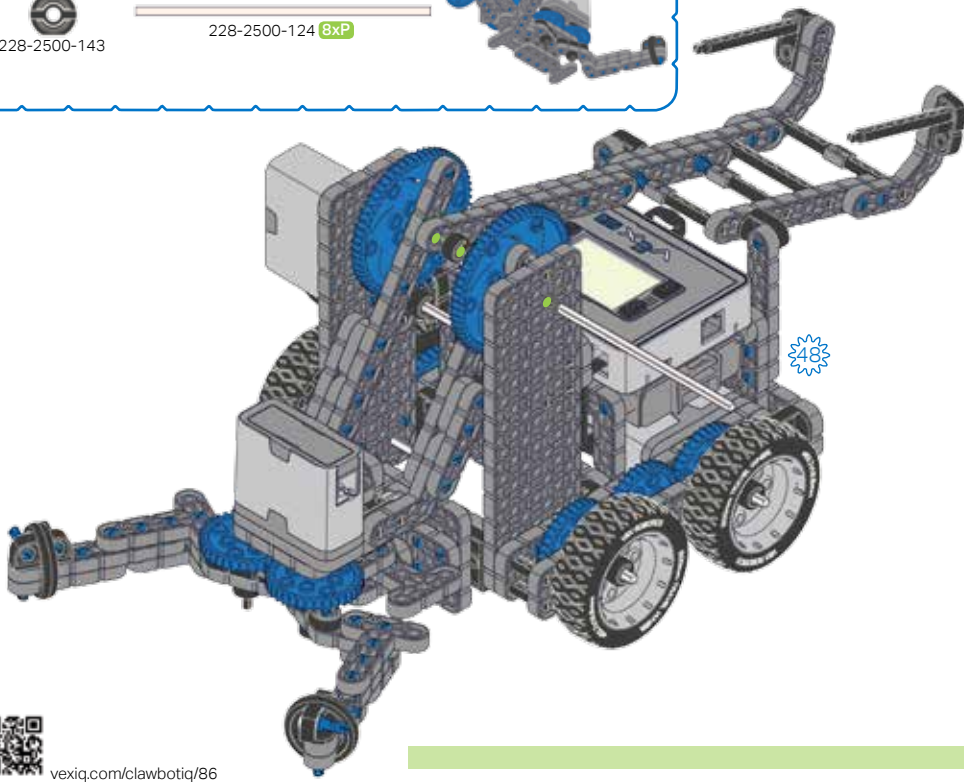
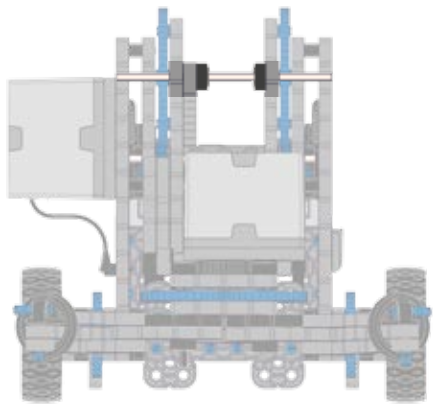
 vexiq.com/clawbotiq/86

 1:1

87



228-2780-004 600mm

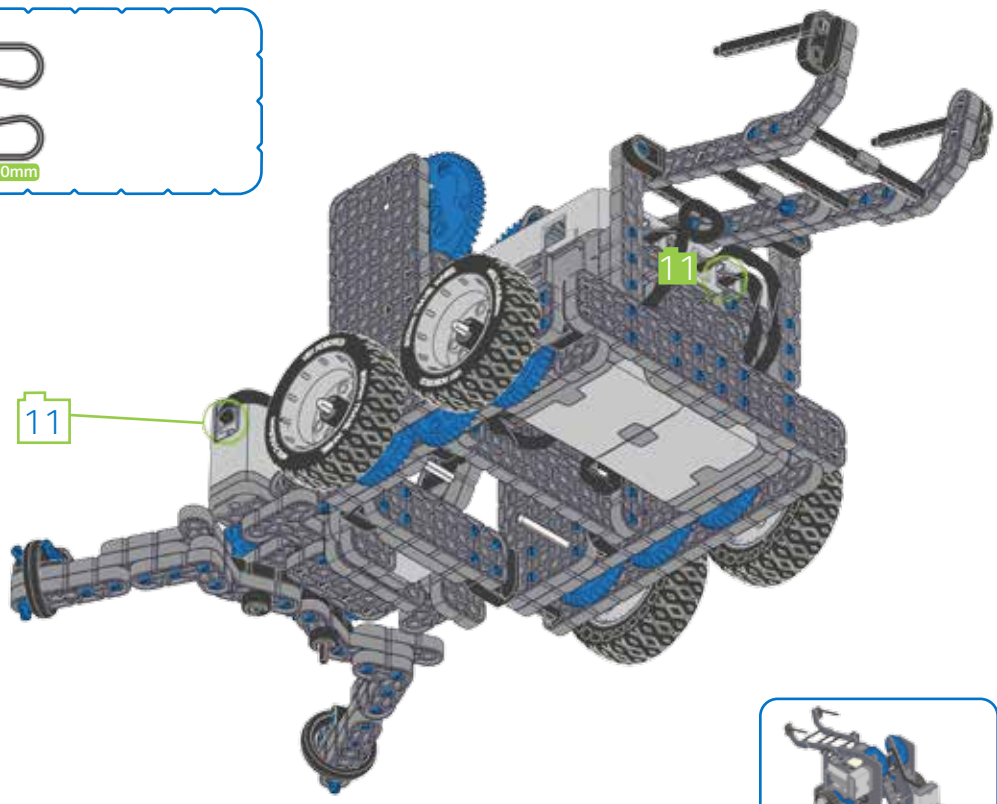

6.1  For information on the Driver Control Program, see: Informationen zur Bedienung siehe Bedienungsanleitung:

 vexiq.com/clawbotiq/87

Clawbot IQ with Sensors

3 Clawbot IQ mit Sensoren

88

4x 228-2500-060

1x 228-2500-134

1x 228-3010

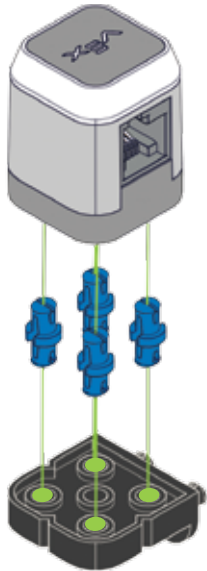

vexiq.com/clawbotiq/88

89

1x 228-3011

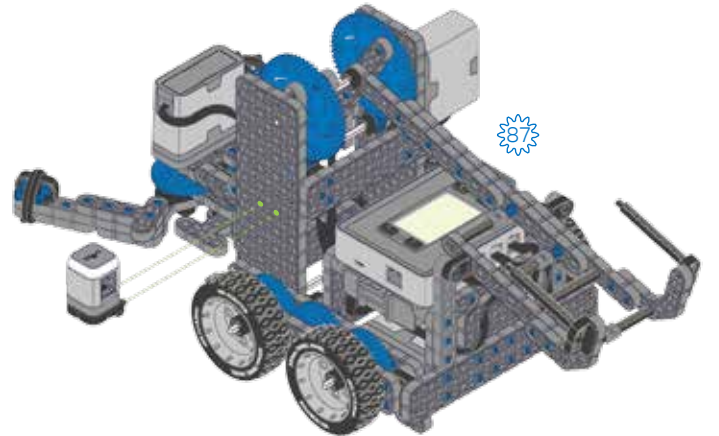

87

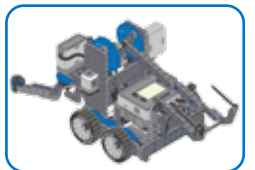

vexiq.com/clawbotiq/89

90

1x 228-2780-001 200mm

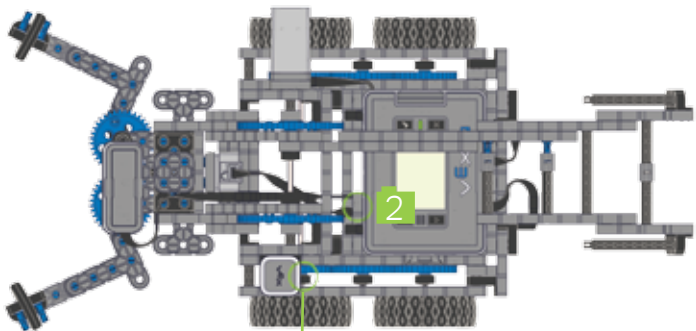

2



vexiq.com/clawbotiq/90

91

4x 228-2500-060

1x 228-3011

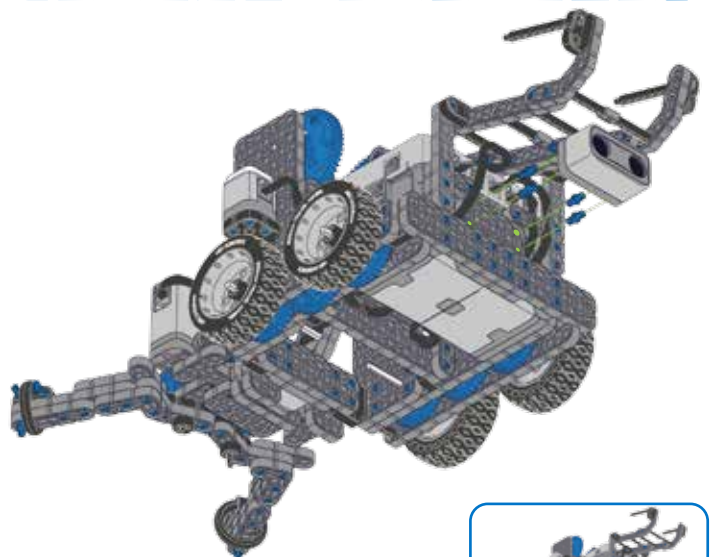

vexiq.com/clawbotiq/91

92

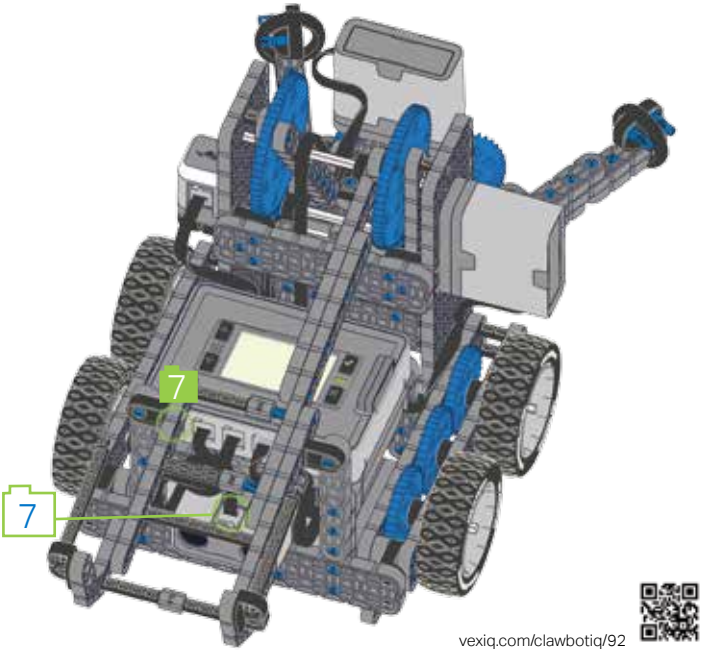
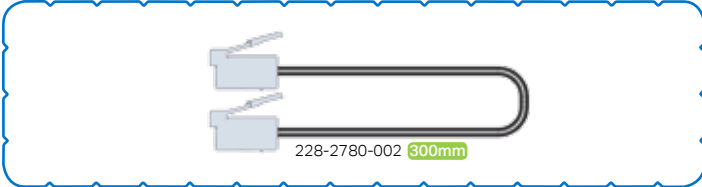

93

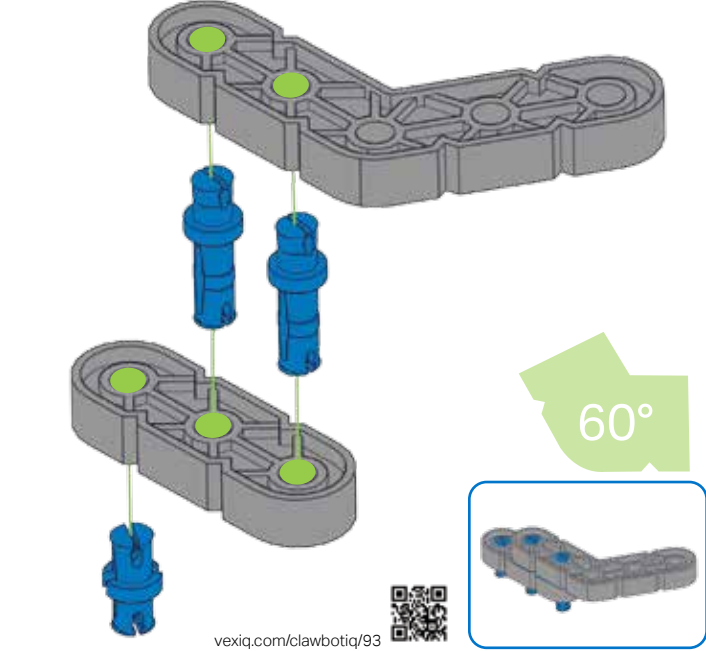
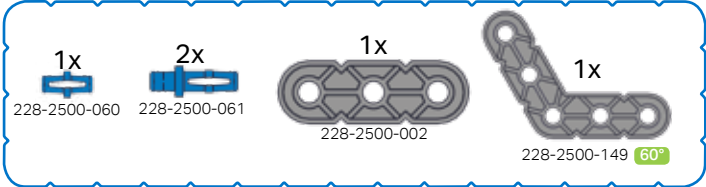

94

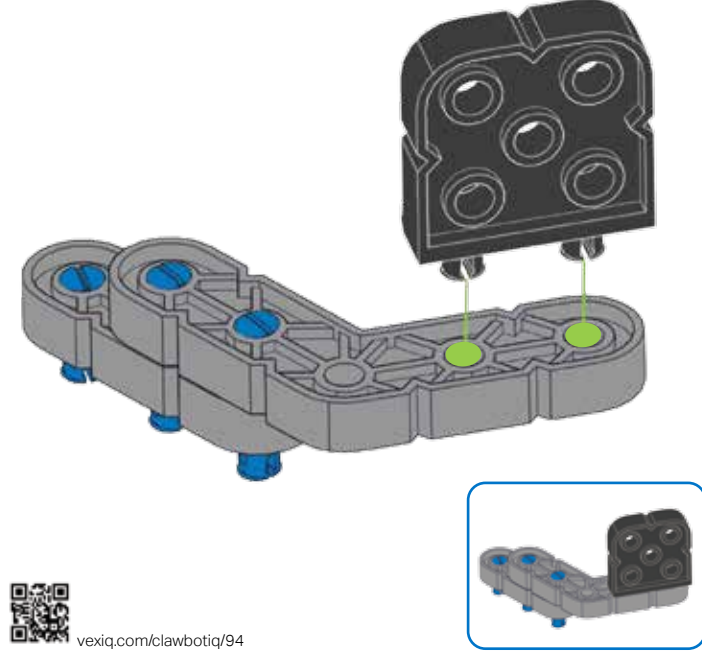
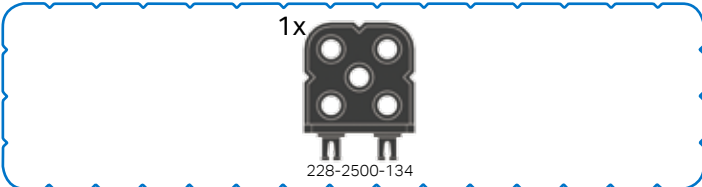

95

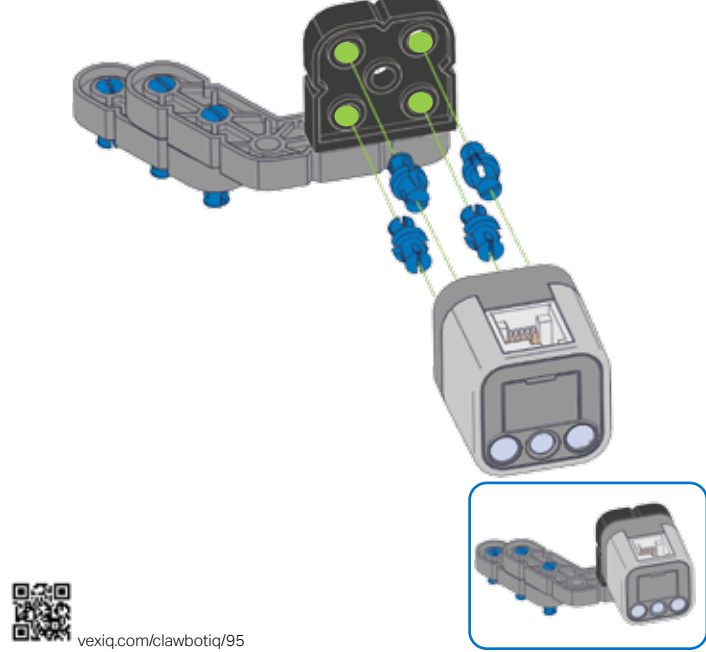
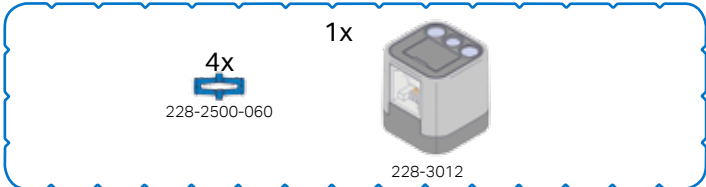

96

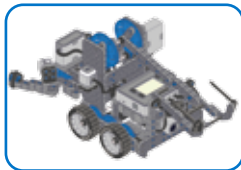
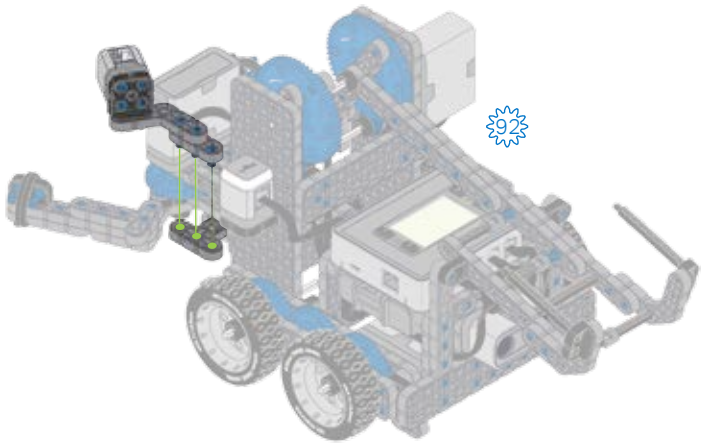

vexiq.com/clawbotiq/96

97

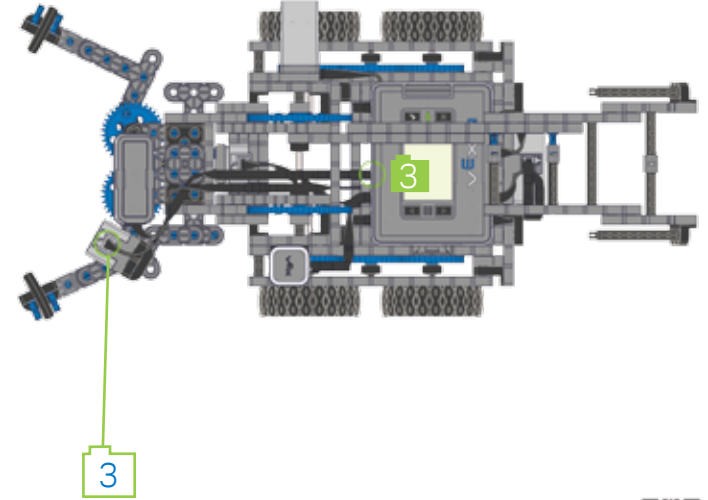
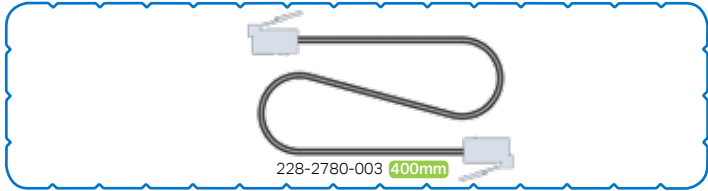

vexiq.com/clawbotiq/97

98

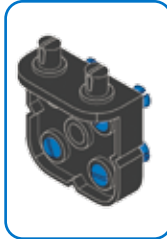
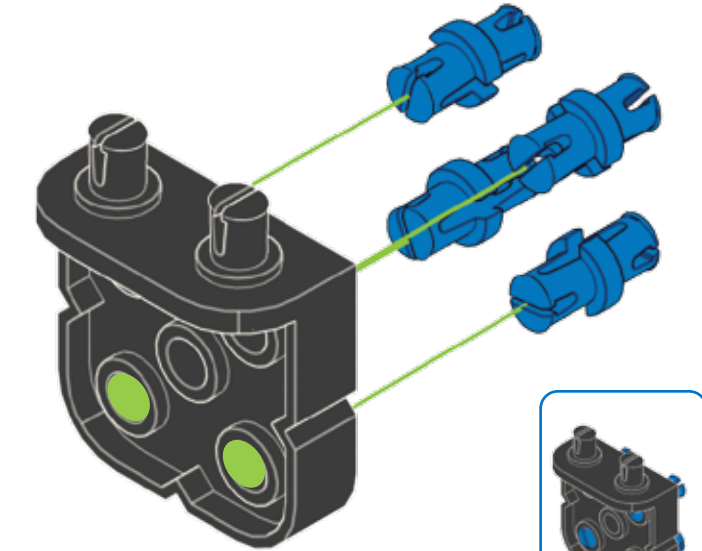
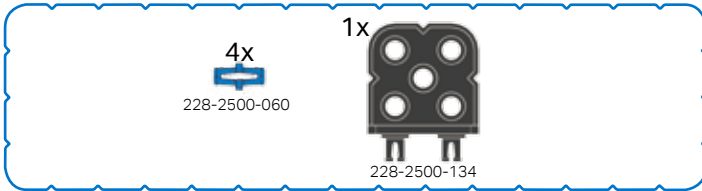

vexiq.com/clawbotiq/98

99

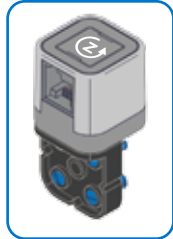
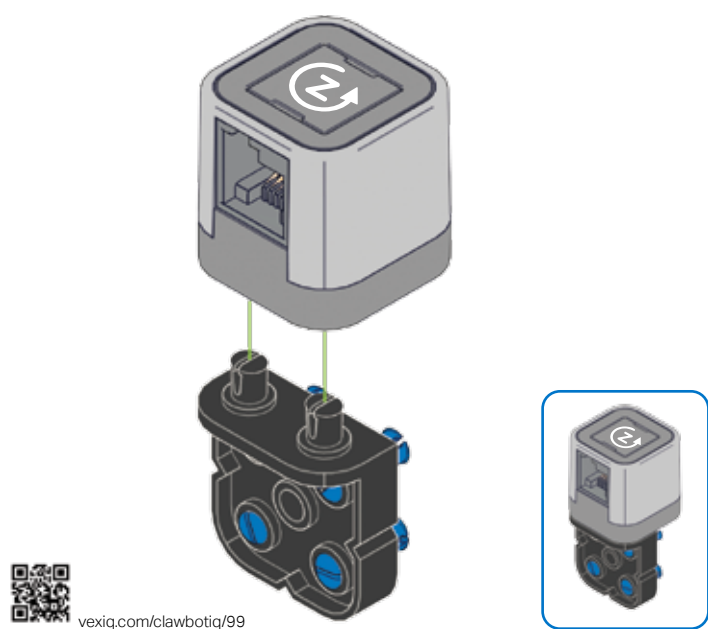
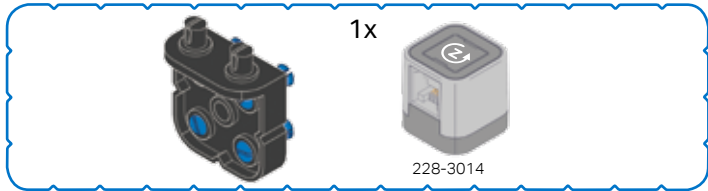

vexiq.com/clawbotiq/99

100

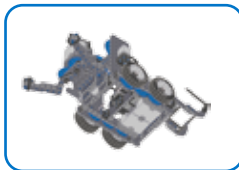
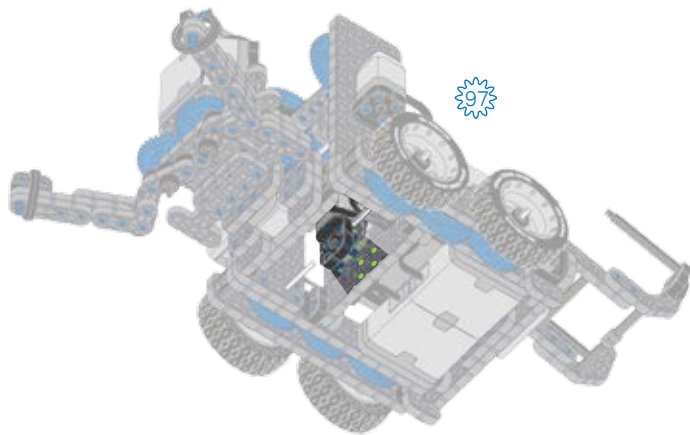

vexiq.com/clawbotiq/100

101

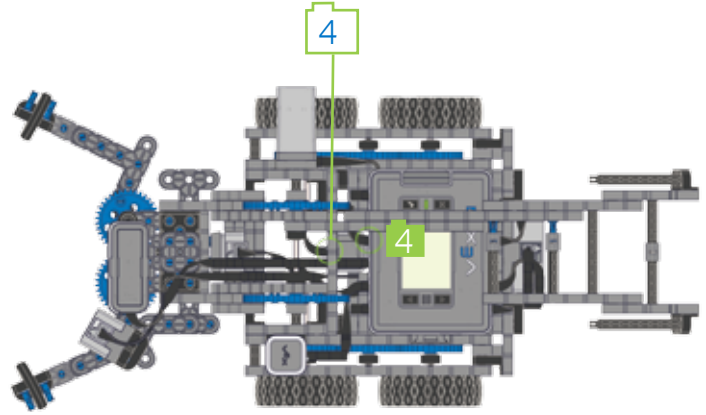
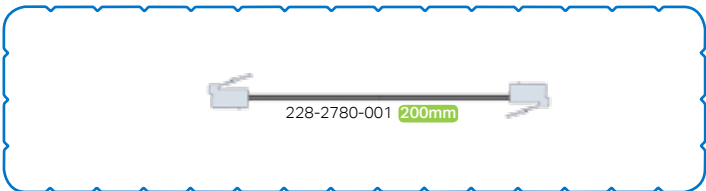

vexiq.com/clawbotiq/101

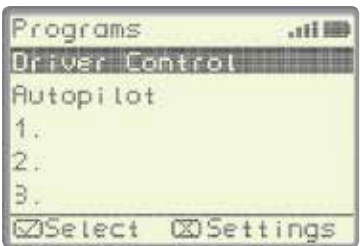

6.1 For information on the Driver Control Program, see: Informationen zur Bedienung siehe Bedienungsanleitung:

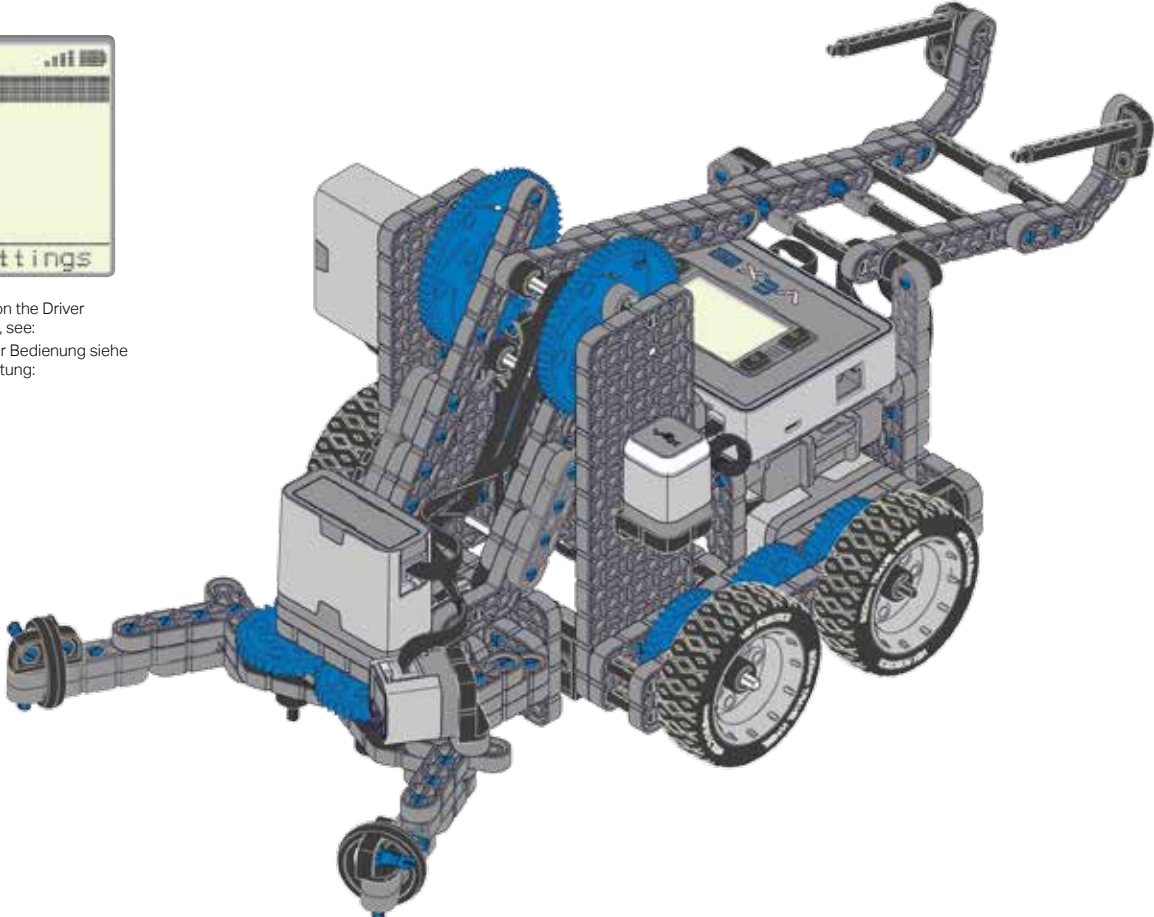

4 Autopilot Instructions

Autopilot

102

6x
228-2500-060

2x
228-2500-126

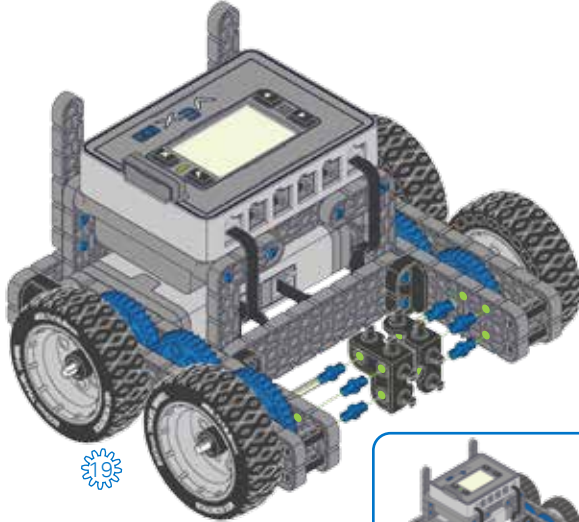

vexiq.com/clawbotiq/102

103

2x

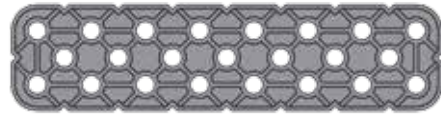

228-2500-023

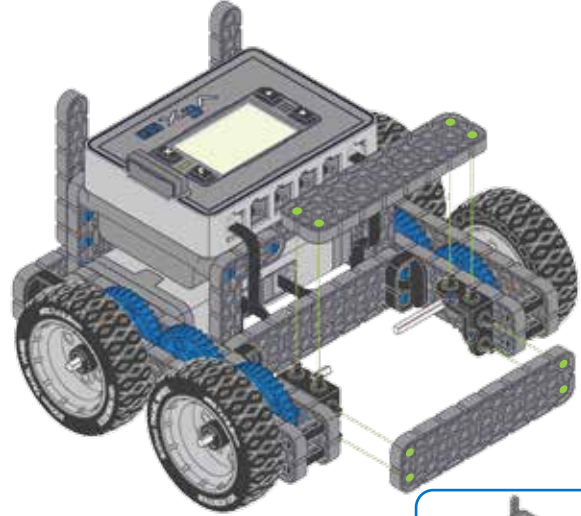

vexiq.com/clawbotiq/103

104

4x
228-2500-060

1x
228-3012

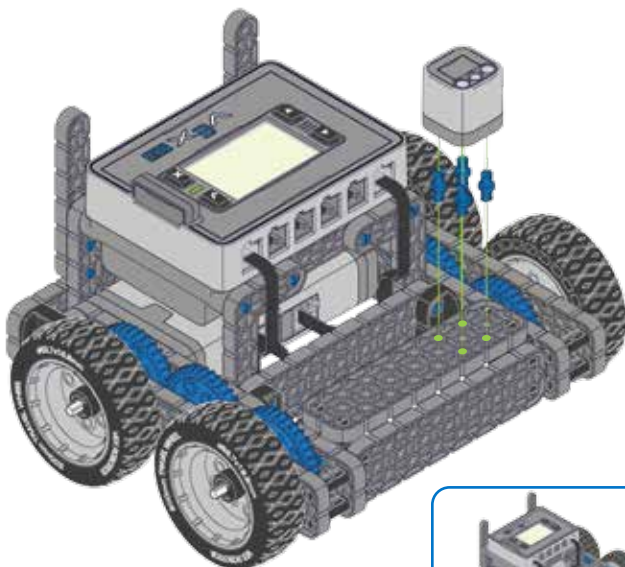

vexiq.com/clawbotiq/104

105



228-2780-002 300mm

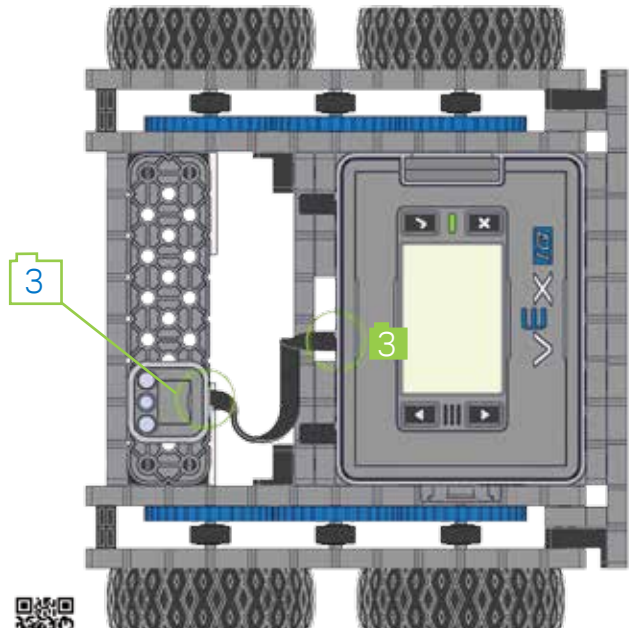

vexiq.com/clawbotiq/105

106

4x
228-2500-060

1x
228-3014

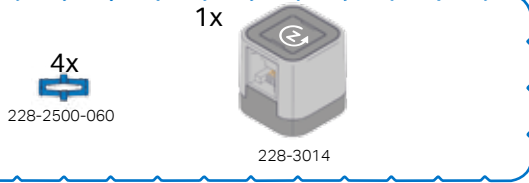
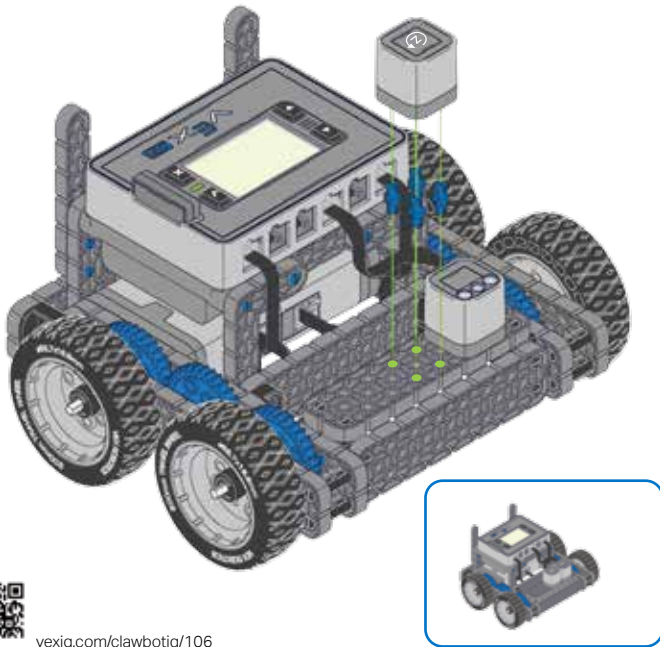
107

228-2780-002 300mm

108

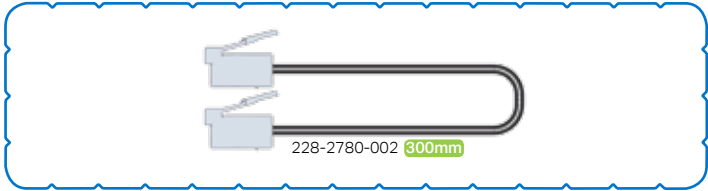
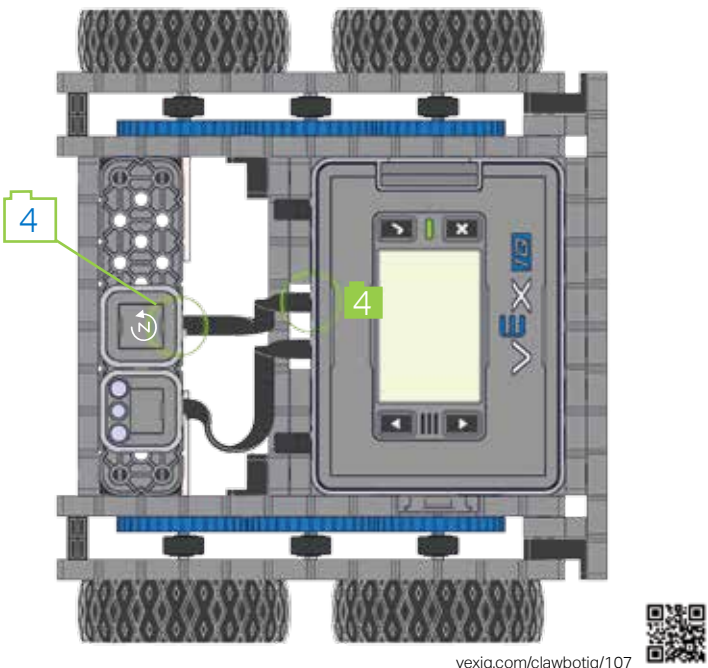
4x
228-2500-060

1x
228-3010

109

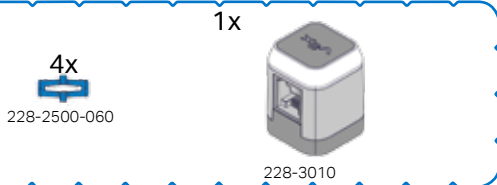
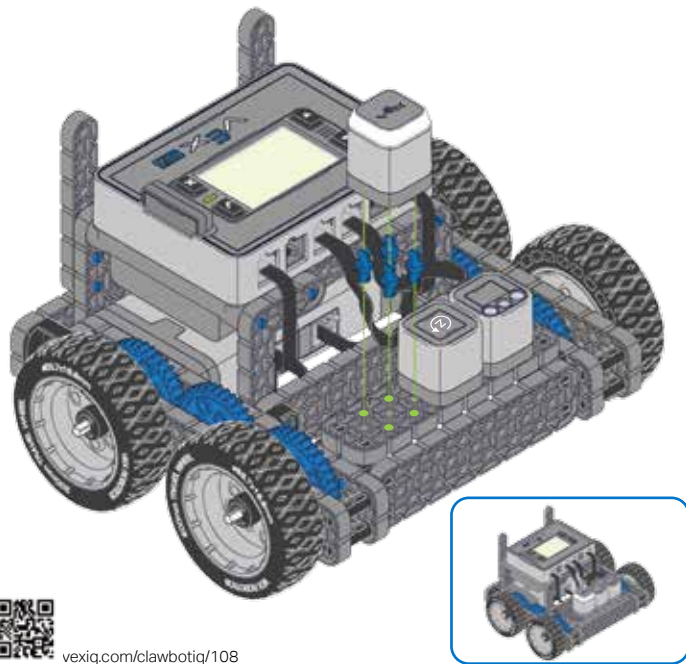
228-2780-002 300mm

110

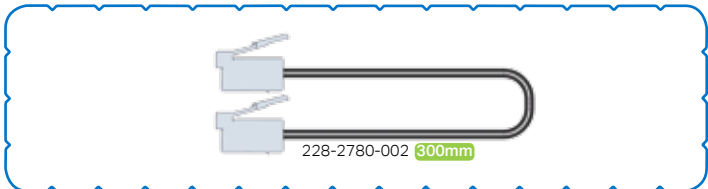
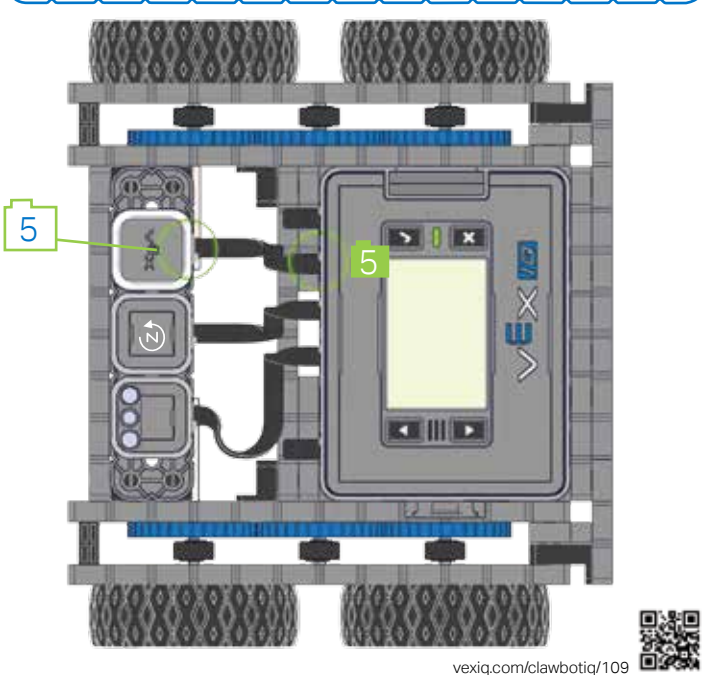
8x
228-2500-060

1x
228-2500-040

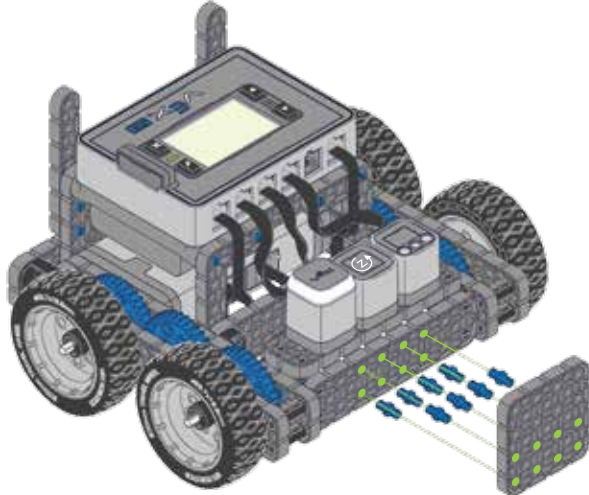

vexiq.com/clawbotiq/110

111

4x
228-2500-060

1x
228-3011

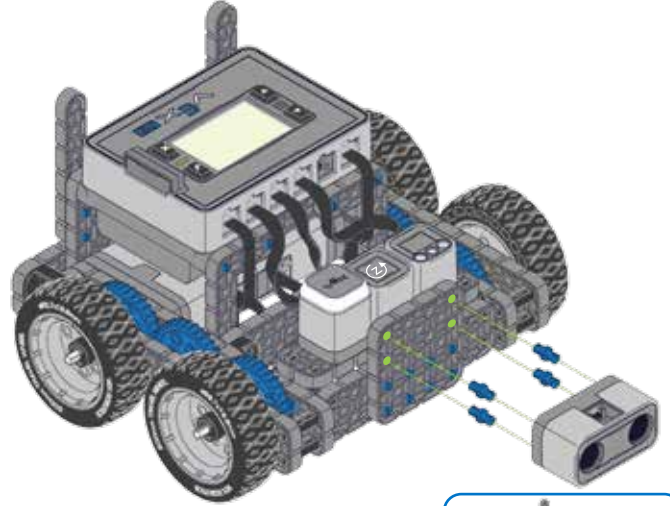

vexiq.com/clawbotiq/111

112

228-2780-002 300mm

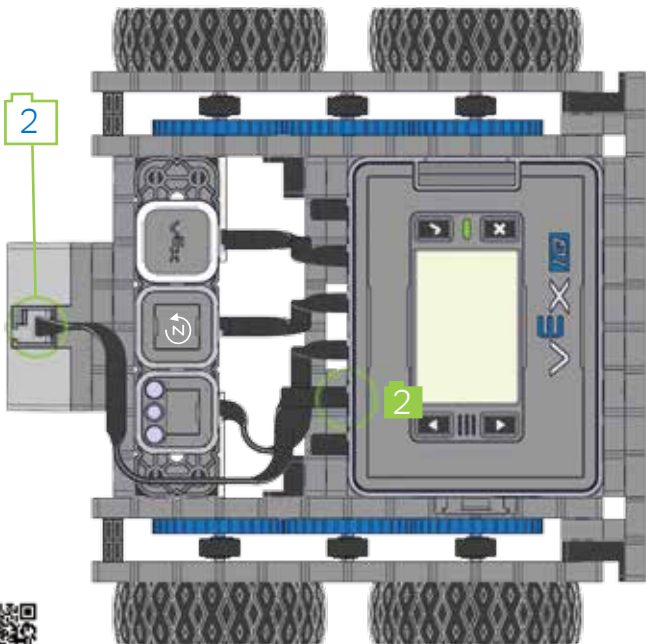

vexiq.com/clawbotiq/112

113

2x
228-2500-060

1x
228-2677

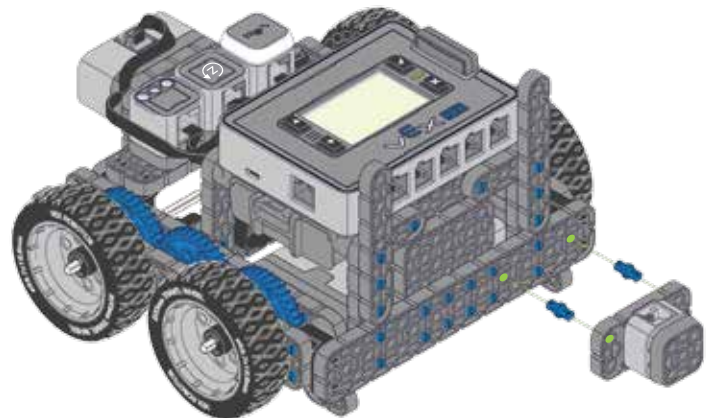

vexiq.com/clawbotiq/113

114

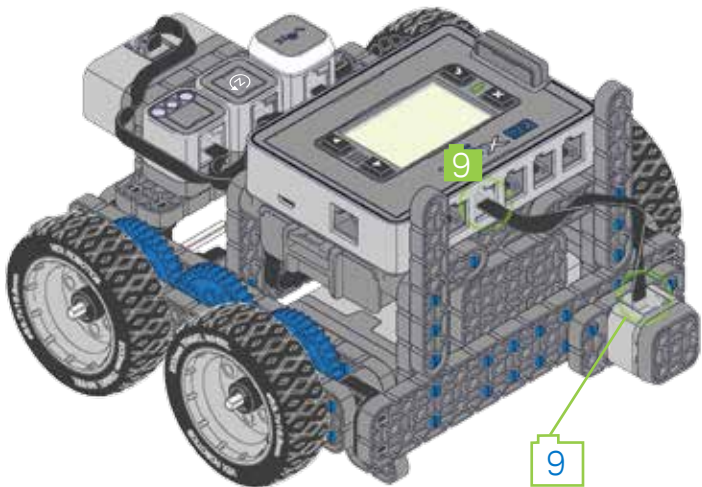
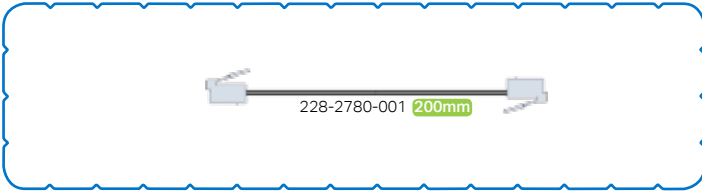

vexiq.com/clawbotiq/114

115

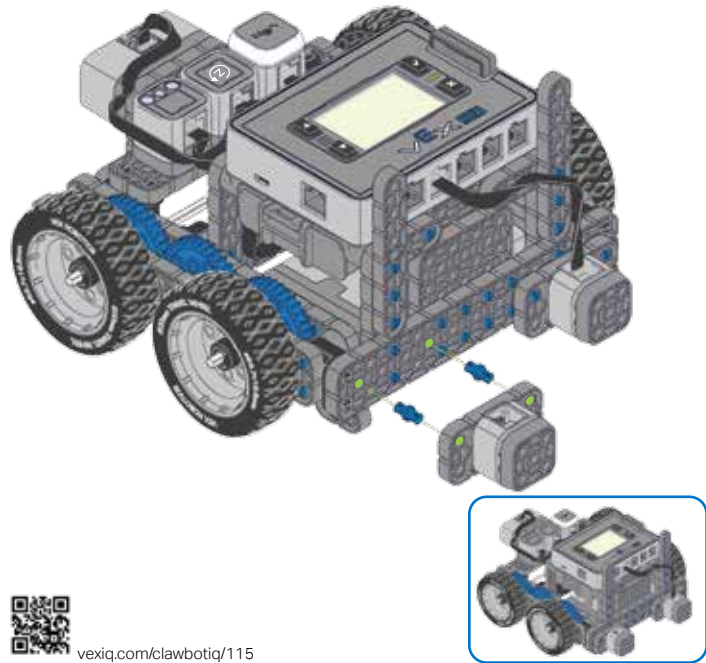
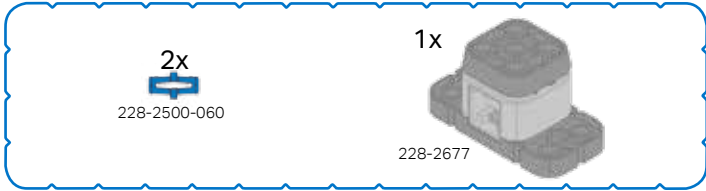

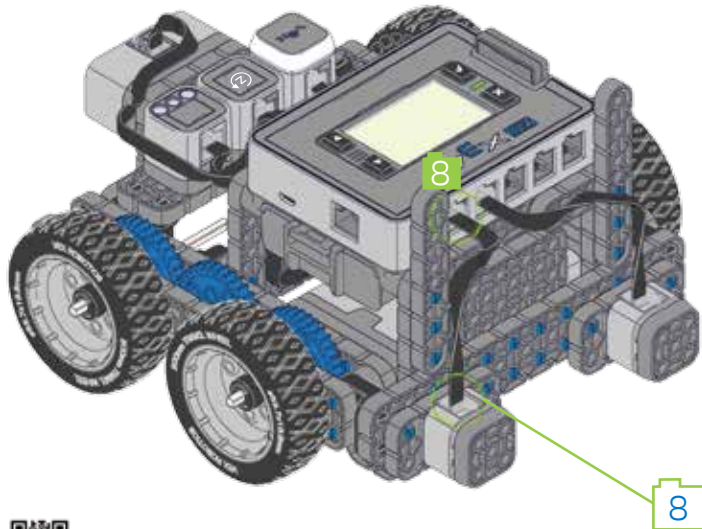
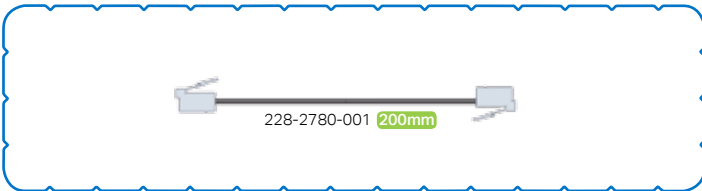

vexiq.com/clawbotiq/115

116

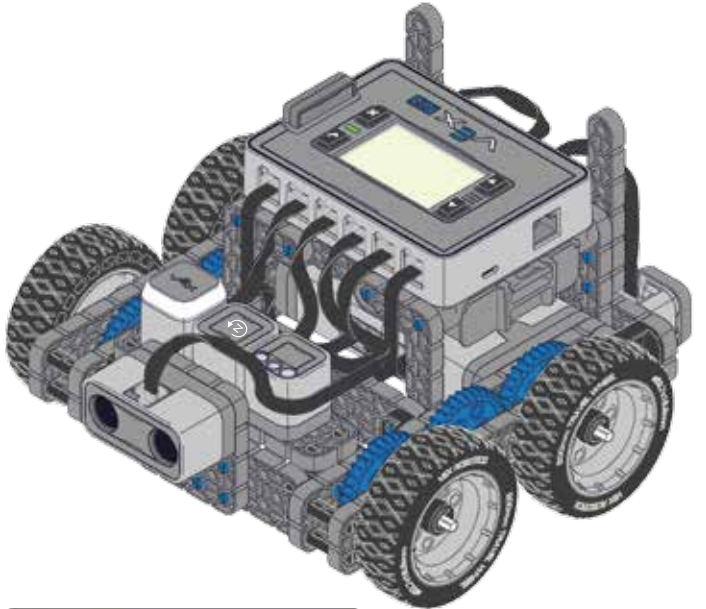

vexiq.com/clawbotiq/116



6.2  For information on AutoPilot Program see: Informationen zur Bedienung siehe Bedienungsanleitung:



Build Instructions Montageanleitung

Ages 8+
Alter: ab 8

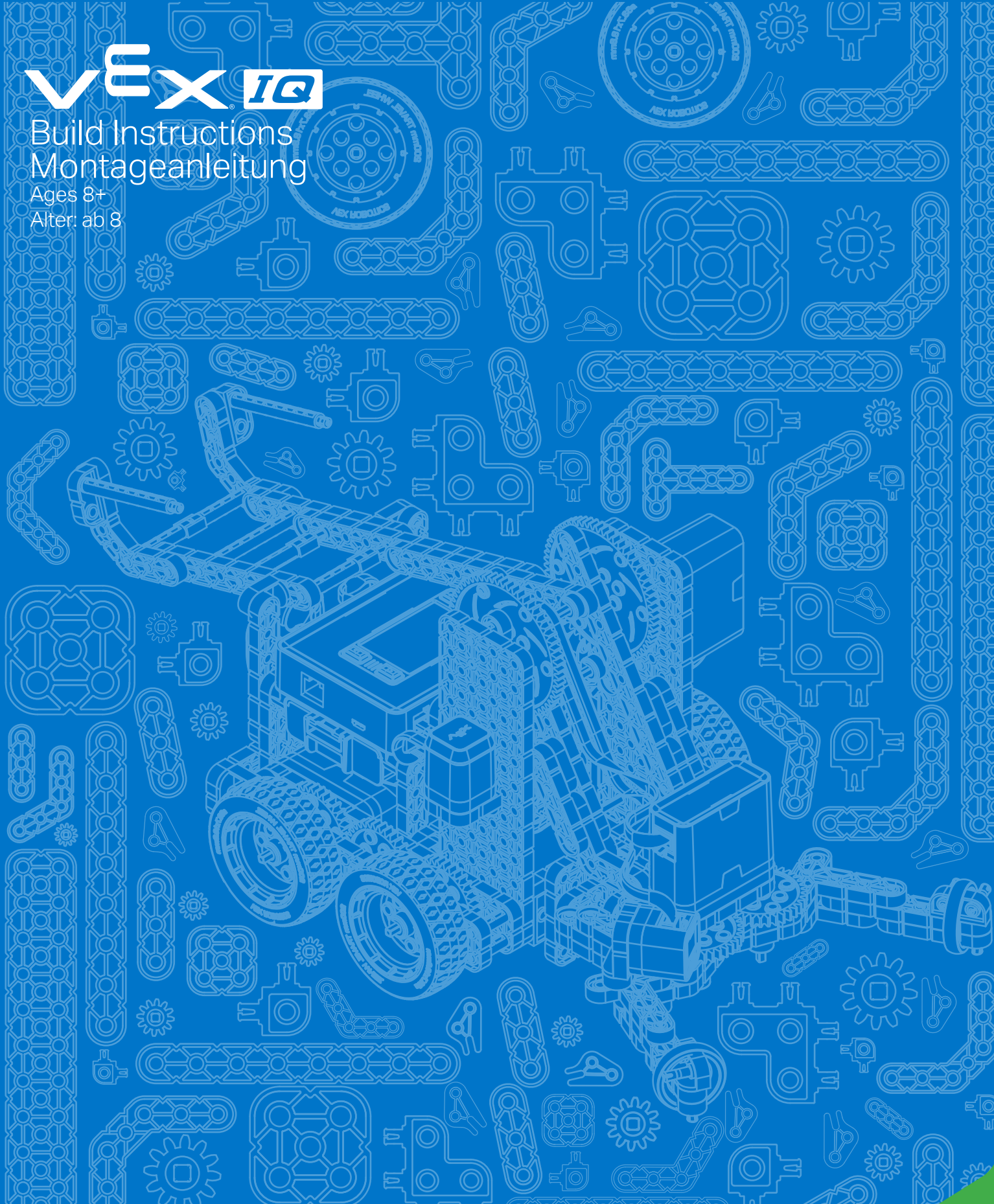

228-3428-750 Rev10

Custom manufactured in China for Innovation First Trading S.A.R.L. Distributed in the U.S.A. by VEX Robotics, Inc., 1519 Interstate 30 West, Greenville, Texas 75402, U.S.A. Distributed in Europe by Innovation First Trading S.A.R.L., 21b rue Gabriel Lippmann, L-5365 Munsbach, Luxembourg +352 27 86 04 87. Distributed in Canada by / Distribu  au Canada par / Innovation First Trading, Inc., 1519 Interstate 30 West, Greenville, Texas 75402, U.S.A.

This product is solely intended to be used as part of the VEX IQ system. Dieses Produkt ist ausschlielich als Teil des VEX-IQ-Systems gedacht.



www.vexiq.com

3428



8 07648 03428 8